

Comparative Study on Efficiency Analysis of Fixed and Dual-Axis Solar Tracking System

Ajay Oli¹, Saugat Sharma¹, Pratham Adhikari², Deepak Neupane¹, Santosh Khanal¹,
Shacheendra Kishor Labh^{1,*}

¹ Department of Mechanical and Automobile Engineering, IOE, Pashchimanchal Campus, T.U., Nepal

² Department of Electronics and Computer Engineering, IOE, Pashchimanchal Campus, T.U., Nepal

(Manuscript Received 30/04/2024; Revised 23/05/2024; Accepted 29/05/2024)

Abstract

Solar energy is a crucial renewable energy source, offering sustainable solutions to address energy demands and combat climate change. Maximizing the efficiency of solar energy harvesting is essential for widespread adoption and integration into the energy landscape. Solar tracking systems play an important role in increasing the efficiency of solar panels by optimizing their orientation towards the sun throughout the day. This research presents a comparative analysis of the efficiency of dual-axis solar tracking systems using Light-Dependent Resistors (LDRs) as input devices. A closed-loop tracking technique is implemented to adjust the position of the solar panels based on real-time sensor feedback. A comparative study between LDRs demonstrates their effectiveness in detecting the sun's position, despite limitations such as susceptibility to ambient light conditions and saturation to light intensity. Through experimental evaluation and data analysis, this study provides valuable insights into the power output and assessment of efficiency variation of dual-axis solar tracking systems offering applications for optimizing solar energy harvesting in practical scenarios.

Keywords: Closed-loop tracking; Dual-axis solar tracking system; Efficiency analysis; LDR sensor; Solar Energy.

1. Introduction

Solar energy is the most abundant and continuous form of natural renewable energy, helping plant growth and playing a crucial role in maintaining the ecosystem. The Earth receives over 120 terawatts of energy from the sun daily. While solar energy contributed for only 11% of global primary power consumption in 2019, Nepal has an estimated annual solar energy generation capacity of around 50,000 terawatts, which is 100 times its hydropower capacity [1]. Once the solar industry develops in Nepal, the cost of electricity from solar is expected to be around NRs 4,800 per MWh, decreasing below NRs 3,600/MWh by 2030 [2].

Solar tracking systems are mechanisms that align photovoltaic (PV) panels, solar collectors, or other solar applications with direct sunlight maintaining optimal exposure and maximizing energy efficiency. These systems can be classified into single-axis and dual-axis tracking systems based on their degrees of freedom. Other types include active, passive, seasonal, and GPS-based tracking [3]. Dual-axis tracking systems follow the sun's movement in both the east-to-west and south-to-north axes. Light-

dependent resistors (LDRs) can be used to identify the sun's direction and adjust the panel orientation through electronic control. Seasonal solar tracking includes tilted single-axis and equatorial dual-axis tracking, while concentrated solar power tracking includes heliostat and parabolic trough tracking. Solar tracking systems can also be classified as open-loop (relying on predefined algorithms), closed-loop

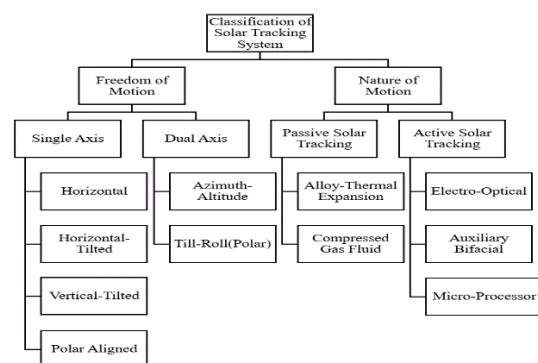

(continuously adjusting panel positions using sensors), or hybrid (combining predetermined paths and sensor feedback for accurate tracking in varying light conditions). The detailed classification of the solar tracking system is shown in Figure 1.

Figure 1: Classification of Solar Tracking System [3].

*Corresponding author. Tel.: +977 9804217868,
E-mail address: sklabh@wrc.edu.np

2. Literature Review

Various studies have shown the significant energy gain potential of solar tracking systems compared to fixed panel systems. Depending on location and season, double-axis sun tracking systems can produce at least 20% and up to 40% more energy than non-tracking horizontal collectors [4]. Tracking systems such as the two-polar axis, north-south, and east-west have shown 135-341% better performance than fixed collectors for freshwater production through desalination [5]. Single-axis trackers typically yield around 20% energy gain, while double-axis trackers can achieve over 40% gain when using fixed paraboloid dish PV systems [6, 8-9]. In suitable locations, the total annual energy gain from double-axis sun tracking ranges from 30-40%, but can be as low as 20% below maximum in very cloudy or foggy areas [7]. Compared to fixed south-oriented tilted collectors, the radiation received by double-axis trackers was 54% higher and the single-axis was 34% higher [10]. Double cover efficiencies were also higher for tracking systems [11]. Experimental tests on tracking systems have shown 9.46-43.55% increased efficiency on sunny days and 18-37.25% on cloudy days compared to fixed flat-plate systems [12, 15-16].

In terms of control strategies, 54.39% of the reviewed works implemented closed-loop, 28.95% open-loop, and 16.67% hybrid-loop [17]. Open-loop systems generally have lower tracking precision, making them less suitable for concentrated solar power and concentrated photovoltaic applications. Hybrid dual-axis trackers can operate much more efficiently (up to 44.44% power savings) compared to continuous tracking while sacrificing little tracking accuracy (around 4.2%) [13]. On sunny days, a solar tracker controller has provided a 26.9% energy gain over a fixed tilted system, while on partially sunny/cloudy days it still yielded a 25.6% improvement [18]. In Nepal's Gandaki Province, identified as having high solar potential, 5.64% of the total area is highly suitable for PV installations, with an average solar radiation of 3.6-6.2 kWh/m² [14].

3. Materials and Methodology

3.1 Materials

The components that have been used in the research are listed below:

Simulation software:

- i. Proteus

CAD Materials:

- i. Solid Works

Electronics Materials:

- i. Polycrystalline silicon solar panel
- ii. Solar panel
- iii. Arduino Nano
- iv. Light Dependent Resistor (LDR)
- v. MG966R servo motor

- vi. ESP 32

3.1.1 Material Specification

Solar Panel

Solar panels use sunlight to generate electricity through the photovoltaic effect, providing a renewable and sustainable source of energy. Polycrystalline type solar panel is used for this research and the detailed specification of solar panel is given in Table 1.

Table 1: Specification of Solar Panel

S. No	Parameters	Specifications
a.	Type	Polycrystalline
b.	Maximum Power	0.65 W
c.	Operating Power Voltage	5 V
d.	Operating Power Current	300 mA
e.	Short Circuit Current	0.7 A
f.	No. of Cell in series	8
g.	Weight	50 g
h.	Surface Area	70 x 70 mm ²

3.2 Methodology

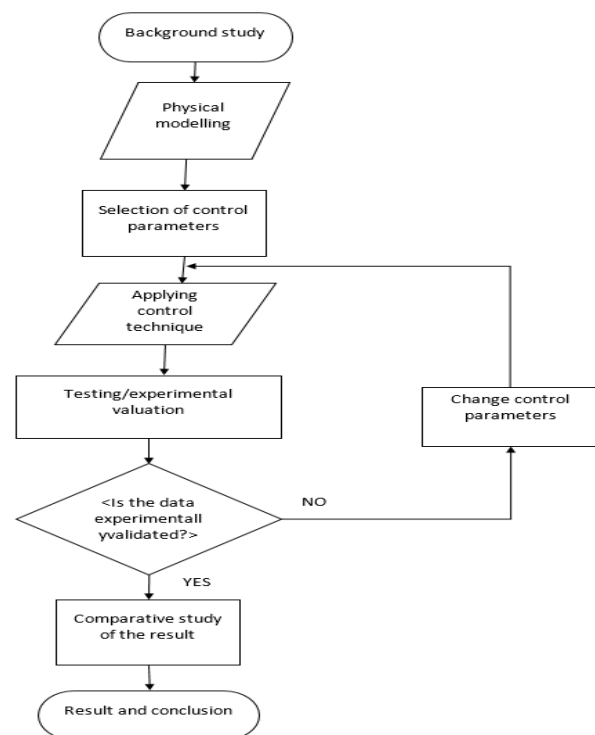

Figure 2: Methodological Chart

This research tries to perform well-designed

quantitative and qualitative research in a very clear and direct way. The methodological chart of the tasks performed from the beginning to the end of the research is shown in Figure 2.

3.3 Experimental Setup

The experiment was conducted at IoE, Pashchimanchal Campus, located at latitude 28.25°N, longitude 83.97°E, and an elevation of 820 meters above sea level, as determined by a global positioning system. The study duration was of 10 days, with some days excluded due to equipment malfunctions, power outages, and internet disconnections. A comparative analysis was performed to evaluate the performance of an LDR-based solar tracking system against a fixed flat-plate system, both using the same PV module specifications listed in Table 1. The experimental setup, shown in Figure 3, was arranged on the terrace of the boys' hostel building in an open area, with the systems oriented in the north-south direction to prevent shading between them during sunrise and sunset. Proper distance between both systems was maintained to avoid shading caused by the Earth's orbital variations around the sun. Therefore, the setups of the examined systems are outlined as follows:

- i. The fixed flat-plate system in Gandaki province, Pokhara, positioned with optimal annual angles at a tilt angle of 28.25 degrees and azimuth angle of 180 degrees, operated without a tracking mechanism, relying solely on operational energy for data collection and monitoring [16].
- ii. The LDR-based solar tracking system utilizes four LDRs configured in a standard arrangement, typical of common LDR-based tracking systems.

4. Construction Method

4.1 Mechanical Part:

The solar tracking system used for this work is shown in Figure 3. It employs a dual-axis design with a primary axis for rotating the module around the north-south (N-S) axis to adjust the daily angle, and a secondary axis perpendicular to the primary axis for rotating around the east-west (E-W) axis. Four small 70x70x5 mm³, 50 gm polycrystalline silicon (pSi) PV module is used. The main platform to support the PV module is 3D printed for lightweight and high-strength properties. Two DC servo motors are installed - one to rotate the primary axis by connecting its shaft to a plate attached to the solar panel, and another to rotate the secondary axis by turning the entire vertical assembly on a horizontal platform connected via a base assembly. This dual-axis design allows accurate adjustment of the module orientation by controlling the two axes of rotation. (pSi) PV module is used. The main platform to

support the PV module is 3D printed for lightweight and high-strength properties. Two DC servo motors are installed - one to rotate the primary axis by connecting its shaft to a plate attached to the solar panel, and another to rotate the secondary axis by turning the entire vertical assembly on a horizontal platform connected via a base assembly. This dual-axis design allows accurate adjustment of the module orientation by controlling the two axes of rotation.

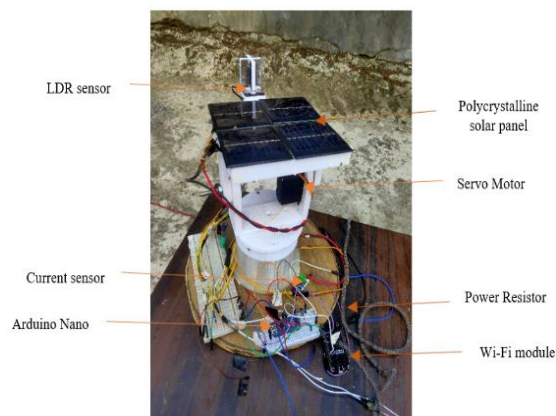

Figure 3: Dual Axis Solar Tracking System

4.2 Electronics Part

The tracking system utilizes four light-dependent resistors (LDRs) placed at the northwest (LDR1), southwest (LDR2), northeast (LDR3), and southeast (LDR4) directions around the PV module. The analog voltage signals from the LDRs, which vary with light intensity, are fed into an Arduino Nano microcontroller. The microcontroller converts the analog LDR signals to digital and processes them as per the tracking algorithm to calculate the average top (LDR1, LDR2), bottom (LDR3, LDR4), left (LDR1, LDR3), and right (LDR2, LDR4) LDR signal values. The difference between top and bottom averages determines the elevation angle error, while the right and left difference gives the azimuth error. A defined threshold (5 to 50) avoids oscillations. If the azimuth or elevation error exceeds the threshold, the system rotates the PV module's axes right/left or adjusts the elevation angle up/down accordingly via motor drivers. Through continuous iterations, adjusting the axes based on the calculated errors, the system aligns the PV module to the optimal position until the errors fall below the threshold. A Node MCU module transmits the data to a computer's backend. The detailed working of the control technique for the tracking system is shown in Figure 4.

4.3 Implementation Models

In this proposed dual-axis solar tracking system, a photovoltaic cell is used to capture solar energy. To demonstrate the effectiveness of this solar distribution generation system, a dual-axis solar tracker is designed, built, and tested. The tracker

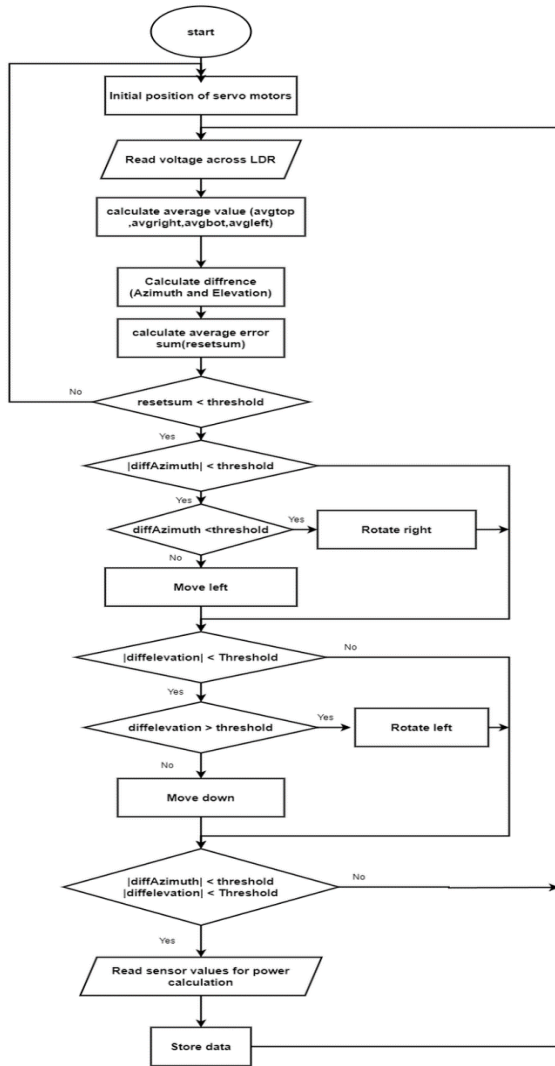

Figure 4: Flowchart of control technique

actively monitors the sun and adjusts its position as needed to maximum power output. In this system, sensors, actuators, and control circuits are controlled by microcontrollers and different kinds of assemblies with supports and mountings.

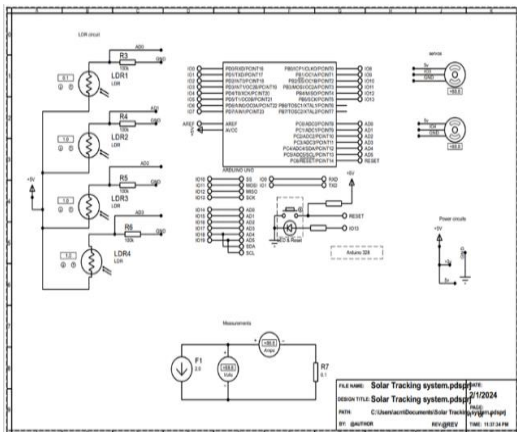

Figure 5: Proteus Simulation

4.3.1 Proteus Simulation

Proteus simulation software allows to design, simulation, and testing of electronic circuits and systems, providing a virtual environment for development and validation. The proteus simulation of the proposed tracking system is shown in Figure 5.

5 Results and Discussions

5.1 Performance evaluation

According to the experiment setup, the experimental results are provided as the following explanations. The voltage and current data generated by the PV systems were measured and recorded automatically every 10 sec for the whole day from 6 am to 6 pm. The input power obtained from the sun on the solar panel is calculated from the given formulas; [19]

$$\text{Power Input, } P_{IN} = \sigma \varepsilon A T^4;$$

where,

$$\sigma = \text{Stefan-Boltzmann Constant } (5.67 \times 10^{-8}), \text{ W/m}^2\text{K}^4$$

$$\varepsilon = \text{Emissivity of the Sun, W/m}^2$$

$$A = \text{Area of Solar Panel, m}^2$$

$$T = \text{Temperature of Surrounding, K}$$

And, the Power Output given by the solar panel can directly be calculated by voltage and current data from the given formula;

$$\text{Power Output, } P_{OUT} = I_{SC} \times V_{OC}$$

where,

$$I_{SC} = \text{Current from the short circuit, A}$$

$$V_{OC} = \text{Voltage from the open circuit, V}$$

Similarly, the efficiency of the proposed model was calculated from the following formula;

$$\text{Efficiency} = (P_{OUT} \times \text{Fill Factor}) / P_{IN}; \text{ where,}$$

$$\text{FF} = \text{Fill Factor}$$

And, the Fill Factor was calculated as;

$$\text{Fill Factor, } FF = \frac{I_m \times V_m}{I_{SC} \times V_{OC}}$$

$$\text{Where, } I_m = \text{Maximum Current, A}$$

$$V_m = \text{Maximum Voltage, V}$$

The comparison between the dual-axis solar tracking system and the fixed solar system shows that in the morning, their efficiencies are similar. However,

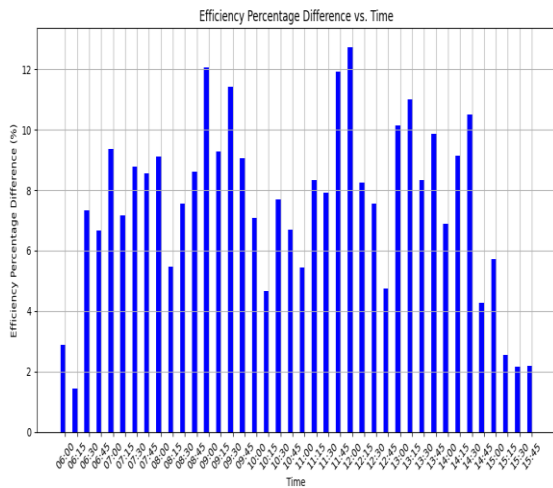

Figure 6: Variation of efficiency with time for fixed and dual axis solar tracker during daytime.

the dual-axis system's efficiency increases rapidly, peaking around noon with a higher efficiency region extending from 10 am to 2 pm, while the fixed system's efficiency rises more slowly which can be seen in Figure 6. After the peak, both systems see a gradual decrease, with the dual-axis system's efficiency dropping below 2.5% due to reduced solar radiation intensity towards the end of the day. The experimental results show that the proposed tracking system produces more active power than the fixed flat-plate system.

5.2 Performance Analysis of Efficiency v/s Time

The power difference is slight from 11 am to 12:20 pm when sunlight is nearly perpendicular but becomes most significant from 2 pm onwards as the tracking system follows the sun's movement while the fixed system cannot adjust its angles. From Figure 7, it can be concluded that the tracking system's average energy efficiency increased by 7.7% and reached up to 12.5% compared to the fixed system during the intermittent cloudy day testing, despite some unusual power output variations due to the cloud cover.

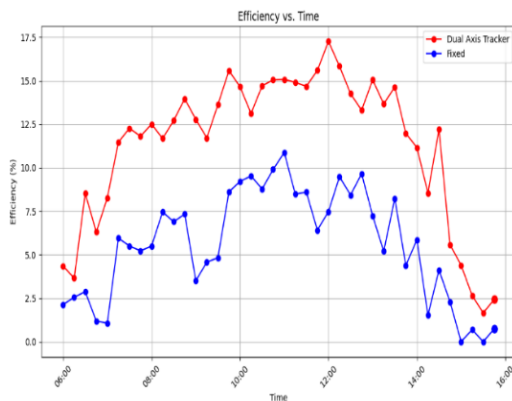

Figure 7: Efficiency Percentage Difference versus Time of

6. Conclusion and Recommendations

6.1 Conclusion

In this research work, the automatic dual-axis tracking system was designed, developed and tested. The tracking system design was proposed to accurately adjust the PV module via the primary and secondary axes to follow the sun path using the sensor input of LDR sensor. For this tracker, it employed a sensor-based closed-loop tracking mechanism in which the LDRs were utilized and installed using a simple configuration that can reduce tracking errors caused by the complicated orientation. The experiment was set up to validate the efficiency of the proposed tracking system in different temperature conditions in Pokhara, Gandaki province, Nepal. In this comparative study, the proposed tracking system was experimentally evaluated and compared with the fixed flat-plate system, and the average efficiency increase of the proposed system is found to be 7.7% and can reach up to 12.5% more than that of the fixed system.

6.2 Recommendation

- i. The testing of the system should be done in variable environmental and weather conditions with different temperature ranges, solar irradiance levels, and weather conditions which ensures the system's performance under diverse real-world scenarios.
- ii. The use of advanced sensors such as pyranometers and advanced UV sensors in addition to advanced tracking algorithms should be used for better tracking and enhanced energy generation with increased efficiency.
- iii. The experiment should also be carried out in a large-scale solar module with an extensive focus on mechanical design and testing to explore its effectiveness in real-world applications.
- iv. A detailed economic analysis of the solar tracking system should be done to determine its cost-for-value ratio and payback duration.

Acknowledgment

This work is supported by the Research and Management Unit, IOE, Pashchimanchal Campus, Nepal.

References

- [1] Bojek, P. Solar PV- IEA, IEA 50. [Online]. Available: <https://www.iea.org/energy-system/renewables/solar-pv>. [Accessed: 2-May-2024].
- [2] Smart Solar, Solar PV in Nepal: A Bright Future for Clean Energy. [Online]. Available: <https://smartsolar.com.np/solar-pv-in-nepal-a-bright-future-for-clean-energy>. [Accessed: 2-May-2024].
- [3] Ya'u Muhammad, J., Tajudeen Jimoh, M., Baba Kyari, I., Abdullahi Gele, M. and Musa, I. A Review on Solar

- Tracking System: A Technique of Solar Power Output Enhancement. *Engineering Science*, 4(1) (2019) 1. doi: 10.11648/j.es.20190401.11.
- [4] Njoku, H. O. Upper-limit solar photovoltaic power generation: Estimates for 2-axis tracking collectors in Nigeria. *Energy*, 95 (2016) 504–516. doi: 10.1016/J.ENERGY.2015.11.078.
- [5] Gholinejad, M., Bakhtiari, A. and Bidi, M. Effects of tracking modes on the performance of a solar MED plant. *Desalination*, 380 (2016) 29–42. doi: 10.1016/j.desal.2015.11.015.
- [6] Parthipan, J., Nagalingeswara Raju, B., and Senthilkumar, S. Design of one axis three positions solar tracking system for paraboloidal dish solar collector. *Materials Today: Proceedings, Elsevier Ltd*, (2016) 2493–2500. doi: 10.1016/j.matpr.2016.04.167.
- [7] Yilmaz, S., Riza Ozcalik, H., Dogmus, O., Dincer, F., Akgol, O., and Karaaslan, M. Design of two axes sun tracking controller with analytically solar radiation calculations. *Renewable and Sustainable Energy Reviews, Elsevier Ltd*, 43 (2015) 997–1005. doi: 10.1016/j.rser.2014.11.090.
- [8] Tomson, T. Discrete two-positional tracking of solar collectors. *Renew Energy*, 33(3) (2008) 400–405. doi: 10.1016/j.renene.2007.03.017.
- [9] Al-Mohamad, A. Efficiency improvements of photovoltaic panels using a Sun-tracking system. *Appl Energy*, 79(3) (2004) 345–354. doi: 10.1016/j.apenergy.2003.12.004.
- [10] Nann, S. Potentials for tracking photovoltaic systems and V-troughs in moderate climates. *Solar Energy*, 45(6) (1990) 385-393. [Online]. Available: [https://doi.org/10.1016/0038-092X\(90\)90160-E](https://doi.org/10.1016/0038-092X(90)90160-E).
- [11] Drago, P. A simulated comparison of the useful energy gain in a fixed and a fully tracking flat plate collector. *Solar Energy*, 45(6) (1978) 385-393. [https://doi.org/10.1016/0038-092X\(78\)90160-3](https://doi.org/10.1016/0038-092X(78)90160-3).
- [12] Kuttybay, N., Mekhilef, S., Saymbetov, A., Nurgaliyev, M., Meiirkhanov, A., Dosymbetova, G., and Kopzhan, Z. An Automated Intelligent Solar Tracking Control System With Adaptive Algorithm for Different Weather Conditions. *2019 IEEE International Conference on Automatic Control and Intelligent Systems (I2CACIS)*, (2019) 315-319. doi: 10.1109/I2CACIS.2019.8825098.
- [13] Ferdous, R. A., Mohammed, M. A., Rahman, S., Salehin, S. and Mannan, M. A. Energy Efficient Hybrid Dual Axis Solar Tracking System. *Journal of Renewable Energy*, 2014 (2014) 1–12. doi: 10.1155/2014/629717.
- [14] Bhandari, A., and Sharma, T. P. P. Suitability analysis of PV solar power plant sites in Gandaki province: Application of GIS and Remote sensing. *Journal of Engineering and Sciences*, 2(1) (2023) 1. Available: nepjol.info [Accessed: 11-May-2024].
- [15] Rajshree, Jaiswal, A. K., Chaudhary, C. and Jayswal, V.K. Development of a Dual Axis Solar Tracking System Using LDR Sensor for Roof-Top Applications. *Recent Trends in Sensor Research & Technology*, 3(3) (2016) 21-26. Available www.stmjournals.com.
- [16] Jamroen, C., Komkum, P., Kohsri, S., Himananto, W., Panupintu, S. and Unkat, S. A low-cost dual-axis solar tracking system based on digital logic design: Design and implementation. *Sustainable Energy Technologies and Assessments*, 37 (2020). doi: 10.1016/j.seta.2019.100618.
- [17] Fuentes-Morales, R. F. Control algorithms applied to active solar tracking systems: A review. *Solar Energy, Elsevier Ltd*, 212 (2020) 203–219. doi: 10.1016/j.solener.2020.10.071.
- [18] Sidek., M. H. M., Azis., N., Hasan., W. Z. W., Ab Kadir., M. Z. A., Shafie., S., and Radzi., M. A. M. Automated positioning dual-axis solar tracking system with precision elevation and azimuth angle control. *Energy*, 124 (2017) 160–170. doi:10.1016/j.energy.2017.02.001
- [19] Al-Naser, Q. A. H., Al-barghooth, N. M., and Al-Ali, N. A. The Effect of Temperature Variations on Solar Cell Efficiency. *International Journal of Engineering, Business and Enterprise Applications (IJEBA)*, 1 (2012) 1. Available: www.iasir.net.