



Far Western Review

A Multidisciplinary, Peer Reviewed Journal

ISSN: 3021-9019

DOI: <https://doi.org/10.3126/fwr.v1i2.62149>

Published by Far Western University
Mahendranagar, Nepal

Vernacular Architecture of a Rural Magar Settlement of Nepal: The Case of Taka, Putha Uttarganga Rural Municipality, East Rukum

Mohan Moorti Pant^{1*}, Ram Prasad Suwal², Sampurna Maharjan¹, Orna Awale³, Rajan Shrestha⁴, Punam Lakha⁵

¹Khwopa Engineering College, Bhaktapur, Nepal

²Nepal Engineering College, Bhaktapur, Nepal

³Off-grid Architects, Lalitpur, Nepal

⁴Kathmandu University, Dhulikhel, Nepal

⁵Architect, Bhaktapur, Nepal

*Corresponding Author: ramps@nec.edu.np

Abstract

The vernacular settlement of the Magar community in the Taka village of East Rukum are still lively, and represent the society, cultural and history of the place, which reflects the sustainable living pattern of a rural community. This study of Taka village clearly defines the geography, settlement pattern, community groups, settlement cluster, social structure, construction of dwelling and rituals. It further identifies the dwelling types and construction technology on the basis of three features: i. representation of each community, ii. representation of each locality, and iii. representation of variation in house form. The settlement pattern and dwelling form in a way represent the characteristics of social structure and life style in the sharing of spaces of the dwelling environment. The dwelling form, building materials and construction technology blends with the terrain profile and climate creating a harmonious settlement pattern with nature and society. There is also community awareness on the conservation of Taka rural settlement heritage which is the positive sign on maintaining the identity of the community and place.

Keywords: Vernacular settlement, Magar, rural community, indigenous construction technology, conservation, place identity

Copyright 2023 ©Author(s) This open access article is distributed under a **Creative Commons**



Attribution-Non Commercial 4.0 International (CC BY-NC 4.0) License.

Introduction

This paper makes study on vernacular architecture of rural Magar settlement of Taka village in Rukum District of Nepal. The major community is Magar who belong to northern Magar ethnic tradition and speak Kham. At present with the 2074 restructuring of local administrative unit of Nepal, Taka belongs to Putha Uttarganga Rural Municipality of East Rukum of Lumbini Pradesh, one of the seven regional administrative units of the federal state. Earlier, Taka was the administrative center of Takasera Village Development Committee (VDC), and now is the center of the Putha Uttarganga Rural Municipality (Fig.1).

Figure 1
Map of East Rukum



Source: https://commons.wikimedia.org/wiki/File:Map_of_East_Rukum.svg

Taka is located 100 m above east of the narrow basin of Uttar-Ganga (called Sano Veri in the lower reaches) facing the basin of Kharimbang stream towards south at an altitude of 2200 m. Kharimbang stream, also called Narsing *kholā* flows past a plain terrain—Chebang, of about one kilometer length and 300 m width before descending down to Uttar-Ganga. Now the flat basin is a fertile farm field of Taka, which also served as an airplane landing strip for about a decade in 2030's.

The village nestles at the lower level of the Nam-ngai mountain where the terrain profile begins a gentler slope of around 1:2.5 and is above the flood level of the Kharimbang stream. The settlement facing south is fortified against the westerly winds by the ridge running along the west side of the village. The major inhabitants of Taka are Magar and Viswakarma. Magar constitutes the primary community with their households constituting about 70%, while Viswakarma community shares 25% in the village. Other communities with few households are Gurung, and Nepali (tailor profession) besides one each of Pun and Roka household, both of Magar community.

With extreme variations in the ecological milieu, there are more than one hundred formally identified ethnic (and caste) communities (CBS, 2014) in Nepal. Nepal-Atlas and

Statistics (Gurung, 2006) lists 41 ethnic communities with a population exceeding 5000. Most of these communities have their particular geographical regions of settlement.

Modern scholars, especially from the discipline of ethnology, began to report on ethnic communities of Nepal inhabiting out of Kathmandu Valley since the 1950's. In *People of Nepal* (Bista, 1967) gives a general introduction of around thirty ethnic communities of Nepal. It was and continues to be a compendium for those interested to understand the diversity in Nepali culture. From 1970 onward, publications focusing on the visual features of a number of communities and their habitat have particularly been presented by foreign scholars. Katherine Blair (1976), Boch-Issacson (1987), and Gerard Toffin edited '*Man and his house in the Himalayas*' are particularly concerned with house and settlement forms (1991). These works brought together a number of articles which introduce the settlements of Newars (Kathmandu), Thakalis (Thak-khola), Tharu (Dang), Limbu (Taplejung), Chetri (Kavre), and high altitude communities of Dolpo and Manang, in addition to those specific communities such as the fishermen in central Nepal and pastoral shelter of highland Nepal. In this cluster of surveys, the study on ethnic settlements of Nepal shows a considerable concentration on the high ranges of the Himalaya, of Mustang in particular (Harrison, 2020). A number of thesis, though unpublished, also make significant contribution in the understanding of settlement culture of this area (Kawabe, 2017; Gurung, 2020). Compared to the wider and long enduring interest to Upper Mustang, studies on other areas and communities of Nepal, however, are almost absent.

A rare exception constitutes the survey of a village of the eastern Magar (Doba) in Myagdi, the Rai in Sankhuwasabha (Yaphu), the Chetri (Kuru) and the Giri (Raut Bada) in Bajura and the Thakuri (Budu) in Mugu in 2000, 2003 and 2006 by the German architect Andreas Brandt (Brandt, 2011). Brandt's excellently rendered drawings present a lively picture of settlement form, dwelling spaces and life style of the place.

So far, only anthropologists such as Anne de Sales and Michael Oppitz did research in villages of the western Magar, De Sales in Lukum (one day's walk from Taka) and Oppitz in Taka. Oppitz's monograph on Taka and its society was published in German (Oppitz, 1991). This book contains the survey of a single house by Gutschow, 1988, while the book presenting *Himalayan Drawings* by Robert Powel has an axonometric drawing of a section of Taka, 1983.

Nepal, at present, is at the threshold of change in many respects. This is already despairingly apparent in the erosion of rural vernacular landscapes. The change, in general, is eroding the local traditions and giving way to new social and physical forms. Rural municipalities are primarily concerned on facilities such as education (schools), health

(hospitals, health posts) and agriculture. However, in the wake of a growing awareness on cultural heritage, there is also a realization of the value of the local tradition. Settlement culture and house form are the essential setting in the meaningful functioning of traditional culture. Architectural survey documentation serves both to raise the awareness of the community and concerned institutions and individuals, and in conservation, restoration and development of the living culture.

Methodology

There are three major different groups in Magar community of Taka—Gharti, Vaijali Budha and Ramjali Budha. At present the three community groups are identified by three different quarters distinct in the settlement division. These quarters are known locally as Gharti-dera, Jethi-dera, and Kanchi-dera. Earlier, until Rana rule, there used to be a chief representing each of these *derā* (Magar, 2005, 2007). In population, Vaijali Budha and Ramjali Budha households of Jethi-dera and Kanchi-dera exceed much in number. From topographical considerations, Kanchi-dera where Ramjali Budha households inhabit is at lower level bordering Jethi-dera at north. Besides the three community locales, the areas of Bika concentration are called Kami-dera which is located further down in the terrain. There is no distance to separate these different community clusters but only lanes as a common pattern of the settlement. Major lanes encircle the settlement or the community cluster. Minor lanes run east west parallel to the terrain contours, and serve as access to the individual dwellings which are arranged contiguously along the lane. One can reach to their dwelling by one of such lanes entering from the main lane or the boundary lane without crossing through adjacent community cluster. A photograph of 1979 (Oppitz, 1981) shows clearly the extent of village settlement upward from the main east west lane as the lower -dera (Fig.2& 3).

Figure 2

Left: A 1979 view of Taka (Oppitz, 1991) & Right: Aerial view of Taka-2021



Source: (Googlemap, 2021)

The settlement of Taka is dense and reaches a density comparable to core areas of a city. In our survey, there are 372 dwellings with 14 ruin sites within the circuit of main lanes covering an area of 3 hectare. Among them 34 are left vacant while 12 have other households living either in rent or some relatives of the owner. It gives 550 people/ha if the data is taken into accounts the average of 5.1 members in a household according to the Environment Assessment Document of Rural Reconstruction and Rehabilitation Sector Development Program, 2011. But the above number gives a picture of the density of social activities some thirty years back before the phenomenal trend of migration to cities in Nepal began.

Results and Discussion

House Types of Taka

Figure 3

A 2021 village view & Plan showing Community Cluster -Dera

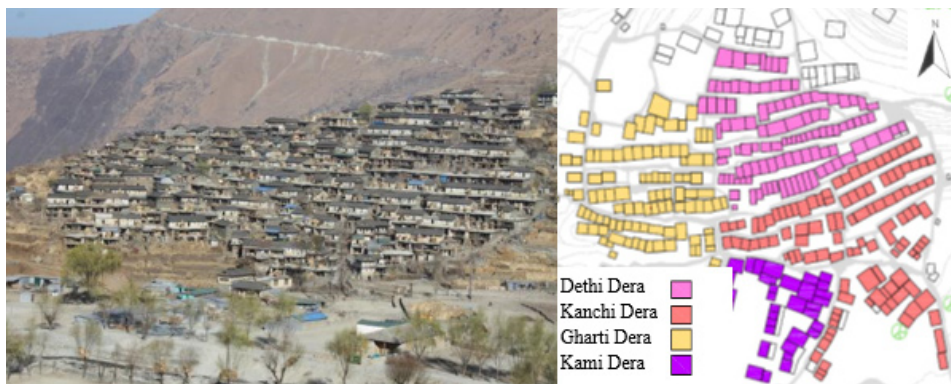

Rural house types within a village show less diversity, and often is difficult to see the difference if any for the casual observer. Historic developments are a matter of detailed research, and often go unrecorded in vernacular literature. One could expect variations by the age of building, by the clan-community or by the topographical feature of the dwelling site. Climate, terrain and building material may play critical role in determining the house form. The climate of Taka situated at an altitude of 2200 m is temperate for the larger part of the year and cold in

Figure 4

Section showing various household functions in different floors



winter with snowfall. The terrain of the settlement faces south; towards the basin of a stream that irrigates the terraces of the village. All houses face south direction with sunshine, and avoid strong westerly winds that rise and blow up through the passage of Sani Veri gorge.

The houses of Taka are built with party walls adjoining each other facing the lane towards south. The adjoined houses form long rows which in some lane is about 100 m. Most of the lanes have more than 10 houses in a row with 4-5 m frontage presenting a street scene not very different from a housing estate built in a city of a million populations.

On average, the dwelling lot is of about 80 m² with frontage of 4-5 m. Cattle are kept in ground floor with space to store fodder and firewood. Upper floor is the living space of various household functions with a wide veranda called *mairā*. Inside is a single common hall space with fireplace. The roof is flat and is used by the community—specially as a front yard by the house of the lane in the upper terrace at the rear of the house (Fig.4).

Figure 5
House types, Extension, Partition and Variation

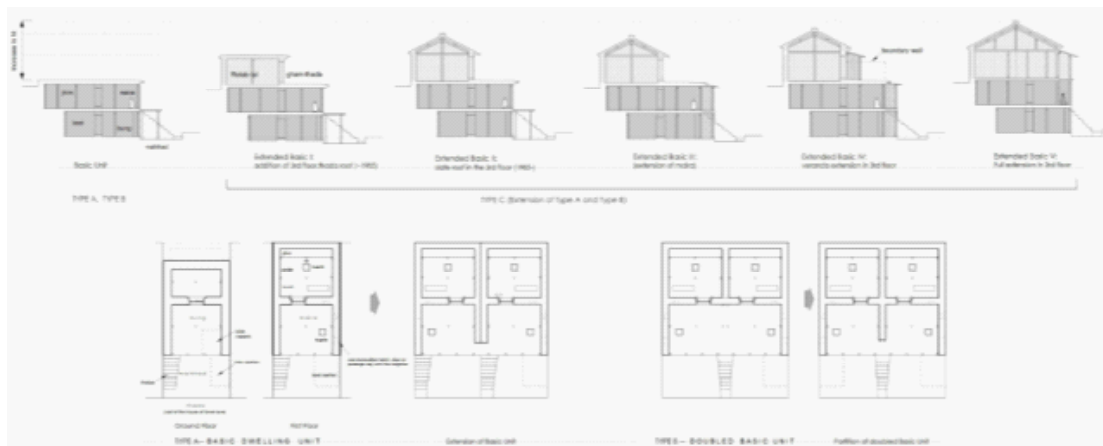

The selection of the houses for survey measurement works are deliberated to meet following features:

- i. Representation of each community
- ii. Representation of each locality—Gharti-dera, Jethi-dera, Kanchi-dera and Kami-dera
- iii. Representation of variation in house form

Consequently, 2 to 4 dwellings are selected from each locality that represents type variations of the houses in Taka. Following the detailed survey measurement works, dwellings of the village are categorized in the following way:

- Type A- Basic dwelling unit

- Type B- Doubled basic unit
- Type C- Extended basic unit

Type A-The Basic Dwelling Unit

In Taka, until 2045, most of the dwellings were only of two storeys, a greater number of which have added a story at the rear side since then. In the ground floor, the front yard is for cattle, part of which was used as pigsty until 2074. The pigsty was a space at one side of the yard separated by a low stone wall. Pigs are now taken out of the village and reared at the periphery where the household owns its own farmland. Cattles, however, are kept here until today. The manure of the cattle is stacked on one of the corner of the yard. The yard is not paved but is given a bed of dry leaves(*sottar*) spread in layers after layers rising up to 45 cm from the ground level before they are cleared away and taken to fields as fertilizer. The cattle are seasonally taken to grazing grounds—to farm fields or further up to highlands from the month of Asār. The front yard space with the cattle is called *malkhād*. Inside, entering from the yard, are rooms, commonly referred as *bā* (बं भुइँतला)—ground floor, usually the front is used to store firewood and farm utilities and tools such as wicker baskets of varying size. Recently a toilet is built in part of this space or in the space for *malkhād*.

The bay further inside provides shelter to cattle in cold season and from rains in the summer season. Part of the room space (*bung*) is used to store fodder. The ground floor is not paved and is not used for living functions.

Figure 6
Type A- Plan of House No. 256: Tej Maan Budha Magar

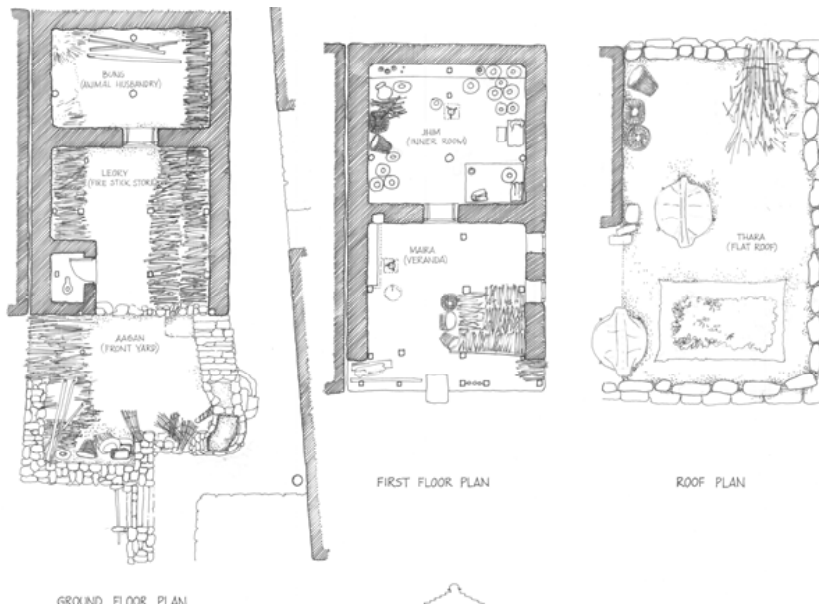

Living functions are in the upper floor. The front is a wide veranda, called *mairā* (मैरा), covering length and breadth of the front bay in the ground floor below. *Mairā* is a vital space of multiple functions. Here is a hearth (खाम: मुठा; अगेनो, चुलो) which is used for all purposes in summer seasons. This is a place for usual reception of guests or where neighbors and folks may gather for meeting or for their pastime. Earlier, one could see grindstone and *dhiki* located here but water mills and later, the electric mills have almost done these tools away from individual houses. In many instances part of the *mairā* front at the ends are used to stack firewood (*haari*). (Fig.6 & 7)

Figure 7

Elevation & Section of House No. 256: Tej Maan Budha Magar

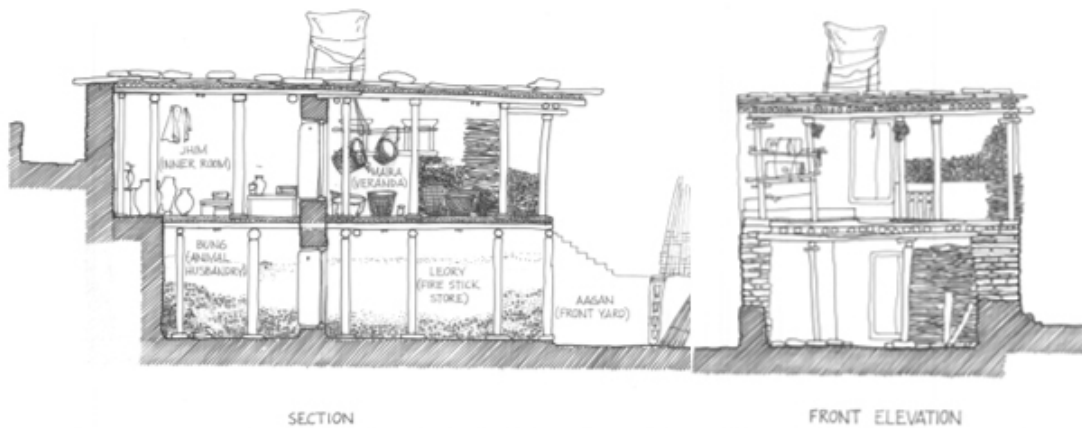

The house through this *mairā* overlooks the lane, the flat roof—*thada* (थाडा) of the house of the lower terrace and then further down to the fields, streams and hills across giving a total view of Taka’s life space.

Inside is the space undivided by walls, but spaces whose usage is articulated from traditional practice. At about the central place is the hearth with a *bhar* hung from floor joists above. North of the hearth is the sacred post of the house, called *maine-khaba* and the space between the hearth and the post is dedicated to *pitri*—the ancestors. Here also dwell *Siddha Varaha* and *bhumidevatā*. On the 8th day of bright lunar fortnight,

Figure 8

Type A- Basic Dwelling Unit and space allocation

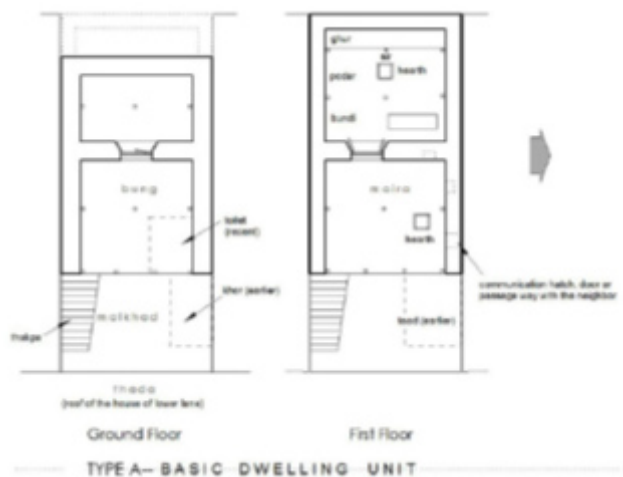

this space is cleaned with cow dung (*ki*) and juniper incense is offered. The space at the back between the wall and the post is called *ghur* where utensil and copper vessels are lined. One could see various size of such vessels carefully lined in order. Large copper vessels are used to store grain and are also inherited from earlier generations (Fig.8).

The east and west section of the central space are called *podar*. From the entrance, the right *podar* is used by the parents and the left is for children. The front of hearth, called *būdi*, is given to guests. *Mairā* is also a space for guests when needed for sleeping. At the North West corner in the wall, Durga is temporarily enshrined during the Dasain season. Without a niche or a particular space, the place is marked by a round pat of cow dung with feathers of cock. Such arrangement of the central room space of the house suggests a ritual hierarchy related to the concept of right and left, top and bottom, front and back with hearth as central reference.

Ground floor and the upper floor is connected by a stone stair (*thapkā*) built at one side of the dwelling. Usually the width of the steps is gradually widened as the stair rises up. One of the carpenters reasons that part of the width of the stair partly supports the free end of the stone wall. This naturally requires upper treads to be made wider at the top to enter the *maira* in the upper floor. This seems to be logical. In not a few instances, two adjoining houses share one stair in common. In such situation, the stair gets V shape form, the reason being the same. Such dwellings are the result of partition from the form of original doubled basic house form is discussed below. (Fig.5, 6, 7 & 8)

Type B: Doubled Basic Unit

This dwelling type, in the nature of its construction and material, number of floor and usage is essentially same with the type A—the basic dwelling unit. The only difference is that it is simply double the size of the basic unit and is mirrored. The stone stair leading to the upper floor is set at the central part. This large size of the house presumes a better economic condition of the owner, and consideration of future division of the house among the scions. In such a house, there are four hearths, two in *mairā* and two in the room inside. Not all hearths are used at all times. However, they are used as necessary to cook and to warm up the house in the winter season as heater. The upper living floor at the interior is bounded only by outer walls of stone masonry. The interior is all supported by timber posts. Later with the division of the house into two, a wall of one *hāt* is built at the central dividing line. In general, a passage is left open at the front end of this wall to communicate between the two units. In earlier times, most of the adjoining houses did have this link left and neighbors and household members of the lane could communicate from one end to the other

according to their convenience. Even today, one could see a number of such units opening to each other. The connecting passage is particularly used during rainy days and snowy winter.

Figure 9

Plans of House No. 31: Nanda Bahadur Budha Magar



There are 44 such dwellings altogether in Taka. There is one with three units, two being the division from the mother unit and the third bought later from the previous owner. The constitution of households in a lane is not so much defined by the genealogical distance. One finds fair mix of households in a lane of a locality. Yet, in one of the lanes of Gharti-dera, the survey finds 7 dwellings belonging to one particular family line (Fig.9 &10).

Type C: Extended Basic Unit

Since 2045 (1988), in Taka, there started a trend to add a room at rear over *thādā*. A 2036 (1979) view of Taka shows that until then most of the houses were of two story with flat roof, only a few houses having added third level (Fig.5). Ranaprasad Gharti recalls his memory saying that a few house with third level existed by 2009 (1952). Ghartiderā had *thādā* type roof while there were slate roofs in Jethi and Kanchi. One of them, in Kanchi-derā, was roofed with wooden boards. House with this floor added is called *talejim*. This nominal probably refers to *thādā* as ground level as reckoned by the households at the back. The room at this level is simply used as additional room space often built with a hearth. The room faces south with a window and door to come out to *thādā*. The part of *thādā* in front

Figure 10

Elevation & Section of House No. 31: Nanda Bahadur Budha Magar

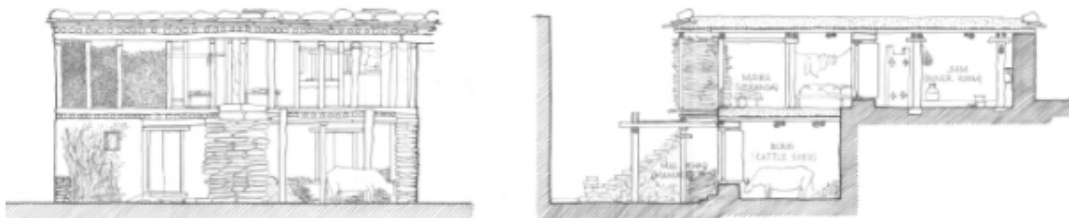

of this room is called *ghām-thādā*, which is just above the *mairā* of the second floor level. In some of the houses, especially with less *mairā* width, the front space of *ghām-thādā* is made a covered veranda.

Figure 11

Plans of House No. 223: Raj Kumar Nepali

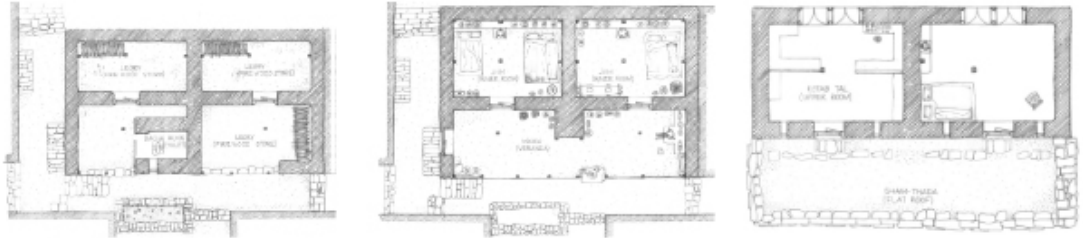

The third floors thus added in those years were of low height compared to that of second floor. With the later trend to add third level with slate roof, the ridge level height almost doubles the height of earlier flat roof. And in some instances, the earlier *thādā* roof has also been changed to slate roof. This addition of the floor with slate roof, although did not make any structural change in layout and arrangement of the house, its impact in the dwelling environment and image of the village is significant. (Fig.11 &12)

Figure 12

Roof Plan, Section & Elevation of House No. 223: Raj Kumar Nepali

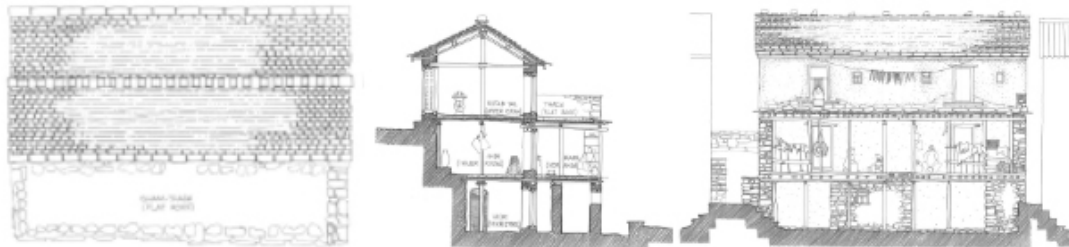

One could assume the need of additional room space to the increased household members during those periods. In general, the impact was considered as not conducive to the living pattern of Taka, and was discouraged by the village committee ruled by the village chief (*mukhiyā*) in earlier times as informed by Ranaprasad Gharti. Survey observation shows the following environmental effects due to this addition over the level of *thādā*:

- Once the third floor at the rear of the house with usual frontage is built, it completely blocked the traditional right of use by the house at the back lane as a front yard and by other village people, the importance of which is noted in the description of the Basic house form.

- The roof is now sloped draining the water both at back and front of the house. Earlier, in the flat roof, all rain water was drained towards the front of the house. This has not only created drainage problem at the malkhād of the house of the lane at the rear, but also is a nuisance to the people when walking through the lane. The issue of dampness existed but with this floor added, the leakage in rainy season is reported to be serious.
- The addition of floor blocks the south sun of the houses at rear which is critically important to cattle in the winter season and to keep the floor dry.
- The new height of the building blocks the southward view from mairā of the houses at the rear side. The issue is not only of aesthetics, more importantly, is of looking after farm fields and the rural ambience.
- While additional space might have been required in 40's, situation has changed now. Not in few instances, there live only older generation leaving the third level without much use.

It is a dilemma now on conservation of the houses of Taka. While the room at the third floor gave a well ventilated and well lit space with *ghām-thādā* at the front, the internal stair gave direct access to the *thādā* level which provided unobstructed front view towards south. But the houses at the back without their floor added suffer from this new change. The situation naturally produced a chain effect—that every house, whenever possible would build its third floor. This situation is particularly apparent in Gharti-dera, where the east west lane are now limited through *malkhād*, an impression entirely different from the past.

Figure 13

Illustrative Diagram: Relationship of Dwelling floor levels, Thada roof level and activities, outward view and terrain profile

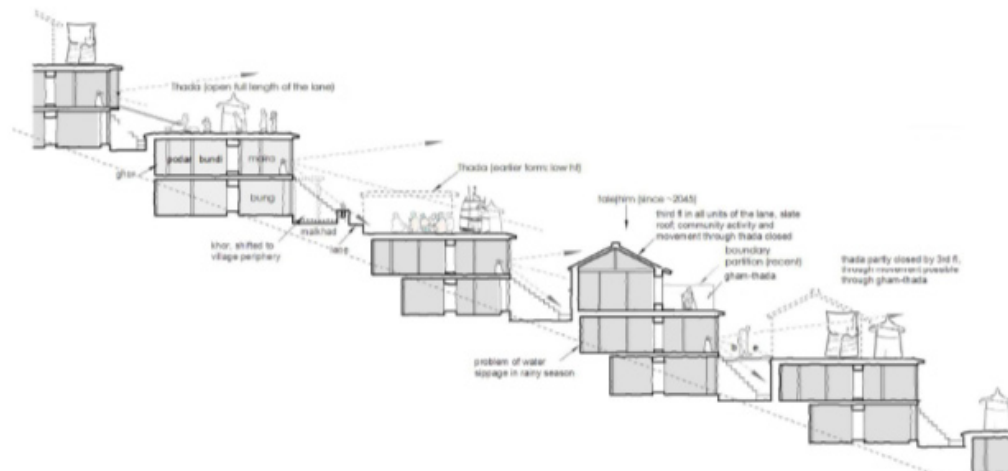

In sum, the addition of third floor has greatly changed the earlier ambience of the village. Another significant chain effect is the trend of fencing the *ghām-thādā*. If this new emphasis on building more private space at the expense of the space used normally by the community goes on as the value of the younger generation, one of the key feature and identity of such settlement will be completely lost. Fortunately, till today, there are some *thādā* without addition of the third floor which still gives a glimpse of earlier shape of the Taka village settlement (Fig. 13).

Construction, Building Material and Structure

All dwellings of Taka are built with stone and mud. Stone masonry is of boulders with minimum dressing. The course level shows variation with the size of the boulder. Thickness of the wall in ground floor used to be one and half *hāt* (~60 cm), and 1 *hāt* in the upper floor. Wall section is either of stepped or gradually tapered from both sides. The tapered form is called *salāmi* style.

Figure 14
Details of the structure member names

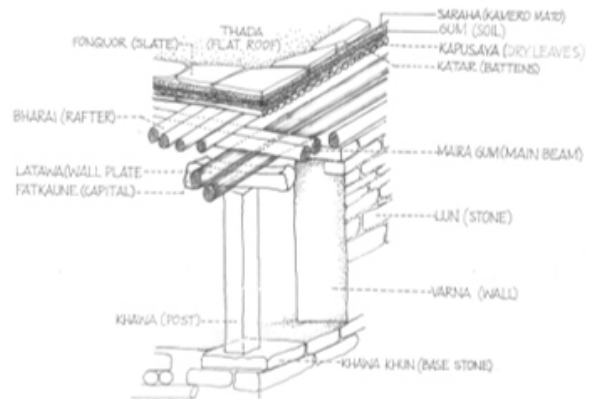

The structure frame is a composite one with timber frame supporting the floor. In most of the instances, row of timber posts are also laid by the side of the walls with beams inserted in the wall thus tying the timber frame with the masonry. Wooden members are always of round timber except that of the front row in *maira*, which are also given square section. A timber plate called *phadkārne*, is inserted in between the post and beam to tighten the joint instead of carpentry joints. Joists are laid close to each other to receive the heavy loads of the floor above. Vedaman Gharti, an elderly carpenter of Taka, mentions types of timber used for different structural members such as *khasru*, *thingre-salla*, *gurās*, *dhupi* for post, while *dhupi-salla* and *khasru* for main beams (*mairāgum*) resting over the posts.

The flat roof is made in layers with *chirpat* base over which a dry grass (*thūki*) is laid upon that works to bond the mud spread over it. A final finishing mix of mud with cow dung is given in the floor surface. The surface requires regular coating, a traditional household task of women.

The roof of the house is flat and is called *thādā*. The flat roof is given a gentle slope going down from the back of the house towards the front draining the rain water from the

stone slabs laid at the edge at a little lower level to speed up the flow of rain water. The roof slope is given when laying the first base course of mud, which is about 5 cm at the front and rises up to 15 cm at rear side. Over this layer is laid a 10 cm thick special type of mud—*kamero*, with lime content. This top layer appears to serve as impermeable with respect to the level of precipitation in Taka. However, the roof surface has to wet and beaten by a wooden hammer to close the cracks that appear in dry season before the onset of rainy season.

Figure 15
Assembling of the structure members

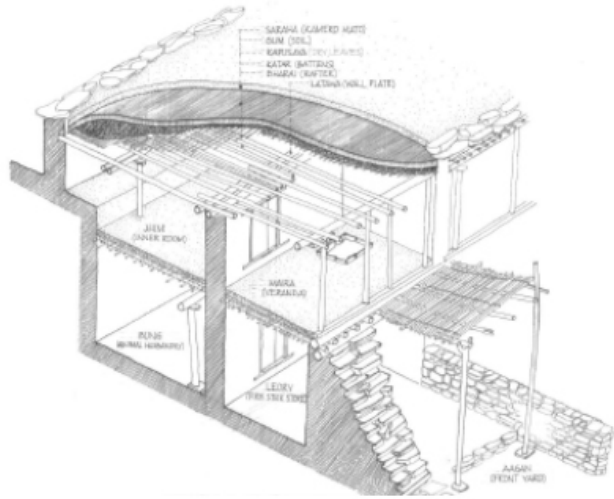

Figure 16
Social activities at Thada



No house of Taka has ladder to go upto the *thādā* except one in Kanchi-dera which has a *thādā* in the first floor as well. The *thādā* of the upper level is accessed from the lower *thādā* through a ladder. It is a custom in Taka that the *thādā* floor is used by the community as a walkway and working space. *Thādā* is also used by children as play space while it also serves as a gathering place of the neighbors. In particular *thādā* is

used by the respective household of the lane in the upper terrace. Thus, *thādā* becomes the extension of the front yard of that house where one finds numerous corn silos of bamboo mat which are covered by woolen blankets or sheltered by round straw canopy. The silos of about 1.2 m diameter and 1.5 m height make spectacular settlement landscape in the winter season following the harvesting of maize sometimes in October-November. The silos gradually disappear when one after another these storehouses are opened and corn is threshed in *thādā*, which then is taken to *ghatta* (water mill) to serve as food for both human and cattle. Besides, in Taka, corn is fermented to distil a high quality wine. Thus, *thādā* is a place for farm work, play and meeting as well as access way connecting the neighbors and villagers.

Conclusion

This survey work is carried out to find out the characteristic of Magar settlement pattern at Taka in which it describes a relationship of socio-cultural aspect with the geographical and environmental aspects of Taka. The dwellings at Taka village are categorized into three types which represent the community, locality and variations and changes in building form. The study also describes the construction technology and techniques of traditional houses built in stone, mud and timber. Inhabitants of Taka are aware of conserving their traditional settlement pattern including the traditional vernacular style though the vehicular road has introduced the new building material and house form. The house form, settlement pattern with adjoined house and use of available building material blend with the topography and climate of Taka.

Acknowledgment

The Research Team would like to acknowledge for the financial support from Gerda Henkel Foundation, Dusseldorf, Germany, and to Saraf Foundation in coordinating this project on the survey study of Taka, East Rukum.

References

- Asian Development Bank. (2011). Initial Environmental Examination. *Nepal: Rural Reconstruction and Rehabilitation Sector Development Program- Karki-Kol-Hukam-Maikot Road Subproject, Rukum District*. ADB Grant 0093NEP, Final Draft Report.
- Brandt, A. (2014). [Painting]. Taragaon Mesuem, Kathmandu, Nepal.
- Bista, D. B. (1967). *People of Nepal*. Ratna Pusthak Bhandar.
- Blair, K. D. (1983). *4 Villages: Architecture in Nepal*. Craft and Folk Art Museum.
- Boch-Isaacson, J. M. (1987). *Architecture and Construction Management in the Highland and Remote Areas of Nepal*. Boch-Isaacson.
- Gurung, A. (2020). *The Concept of 'Cultural Landscape' - A Case of Lo-Manthang, Upper Mustang*. Master's Thesis. Post-Graduate Department of Urban Design And Conservation, Khwopa Engineering College, Bhaktapur.
- Gurung, H. (2006). *Nepal- Atlas and Statistics*. Himal Books for Toni Hagen Foundation.
- Harrison, J. and Pant, M. (2018). *Chimang*. Saraf Foundation for Himalayan Traditions and Culture.
- Harrison, J. (2019). *Mustang Building-Tibetan Temples and Vernacular Architecture*. Saraf Foundation for Himalayan Traditions and Culture.

- Kawabe, S. (2017). *A Study of Village Settlement of Panchgaon Region in Mustang—The Case of Thini*. Bachelor of Architecture Thesis. Nara Women's University, Nara.
- Gharti Magar, R. P. (2005). *Kham-English Dictionary*. Author.
- Gharti Magar, R. P. (2007). *Architecture and Construction Techniques Amongst Magar and Khasa of Nepal*. Dhana Maya Gharti Magar, Takasera, Rukum.
- Oppitz, M. (1981). *Schamanen im Blinden Land. Ein Bilderbuch aus dem Himalaya (German Edition)*. Syndikat.
- Oppitz, Michael (1991). *Onkels Tochter, keinesonst. Heiratsbündnis und Denkweise in einer Lokalkultur des Himalaya*. Suhrkamp Verlag AG.
- Toffin, Gerard. Ed. (1991). *Man and His House in the Himalayas*. Sterling Publishers.