

AN EXPERIMENTAL STUDY ON FLOW FIELD AROUND INUNDATE BELL MOUTH GROIN

¹M. J. Uddin *, ²M. M. Hossain, ³S. A. A. Mamun Hossain

¹Khulna University of Engineering & Technology, Khulna, Bangladesh
²Bangladesh University of Engineering & Technology, Dhaka, Bangladesh
³Patuakhali Science and Technology University, Patuakhali, Bangladesh.

*Corresponding address: jahirce99@gmail.com

Received 14 September, 2011; Revised 29 January, 2012

ABSTRACT

A study was undertaken to investigate the flow field around bell mouth groin in a large mobile bed physical model facility (46m x 11 m). A total number of 24 test runs were conducted. Three different discharges and four different angles and two groin conditions (submerged and non-submerged) was considered. All tests were conducted for 8 hours duration in clear water condition. Velocity data have been collected forming grids in both vertical and horizontal direction around the vicinity of the bell mouth groin. Velocity was measured at 0.2, 0.4, 0.6 and 0.8 depths from the water surface by forming grids. Change in flow conditions around bell mouth groin for various test run have been analyzed non-dimensionally in longitudinal, lateral and vertical direction. The streamwise velocity along lateral direction was found that the lateral shifting of maximum velocity away from the head of the bell mouth groin. In most cases, streamwise vertical velocity in lower part of the channel is found higher than that of upper part. Streamwise vertical velocity profile has been found variable with different discharges and does not follow its natural logarithmic pattern. Velocity vector indicates that flow is steady at upstream along longitudinal direction. The flow diverted at head of structure and flows through sides of structure towards downstream. A circulation of flow has been observed around head of structure after diverting of flow towards down. Immediately after rear front of structure, relatively weak circulation of flow has been observed. In this paper the results of test runs conducted under submerged conditions for 150° and 90° angles are reported.

Key Words: Local scour, Submerged, Non-submerged, Bell mouth groin

INTRODUCTION

Groins are structures that protrude into rivers from the bank and create a flow condition that promotes navigability and diverts the flow away from the bank thereby reduce bank erosion. Recently groins have been received more attention from the standpoint of ecosystem. The design, location, orientation and length of groins are very important subjects for the hydraulic engineers in the field. Basically, it is important to have a clear picture of flow phenomenon around these structures in order to be able to make a safe and economic design. Also, hydraulic conditions such as velocity, water depth, bed shape, and bed material around groins are so diverse to provide the ecosystem with suitable habitat. The development and magnitude of flow behavior for different angle of attacks are still undefined, though flow behavior is of utmost importance to the design of any type of groin. As one of the most popular techniques for riverbank stabilization, groins have already been enjoyed a wide use in a number of riverbank stabilization projects and with a strong tendency to increase its applicability [1].

Over the past several years, there has been a rapid expansion of literatures concerning groins under clear water scour condition in both laboratory experiment and numerical simulation [2, 3]; River course stabilization by groin like structures [4]; River bank stabilization in a bend by groin [5]; velocity distribution in groin fields [6]; Exchange process between river & its groin fields [7]. Kabir investigated the scour reduction

technique and flow pattern around abutment using bottom vanes [8]. Rahman investigated flow field and scouring around piers and abutments [9, 10].

From the foregoing discussion it is apparent that most of the above studies were concerned with pier, embankment, abutment, groin and spur-dikes mainly for assessment of local scour which is very frequently used in Bangladesh. But the development of scientific guiding principles for the bell mouth groin design is yet not fully explained. The reason is that bell mouth groin is typical in the Indian subcontinent including Bangladesh. The flow structure and scour development around bell mouth groin is of great interest for the design of riverbank stabilization projects in Bangladesh. In the present study, which is exploratory and experimental in nature, flow structure around the single groin is investigated for submerged groin. In some locations groins are constructed higher than the high water level, which are called non-submerged groin. In other locations groins are submerged under the water surface. In rivers with unsteady flow conditions, groins can serve as non-submerged in ordinary state or submerged during flood. The area behind the groin is either a dead zone during non-submerged conditions or a slow flow zone during submerged flow conditions. Most of previous investigators published experimental data on the various aspects of the local scour around emerged spur dikes. In their experiments, they have used flow depths that were less than the height of the spur-dike model [11, 12]. Many prototype spur dikes, however, were designed to regularly consider overtopping flow, submerged condition.

EXPERIMENTAL PROCEDURES

The experiments have been carried out in a wide straight flume which is 45.60 m long, 2.45m wide and having a depth of 1m. The flume has a re-circulating water supply system with pre-pump storage pool, post pump upstream, measuring devices, measuring bridge, point gauges, tail gates, sediment trap and stilling basin etc. The water passed through an approach upstream reservoir provided with a series of baffles. These baffles distributed the flow uniformly over the entire width of the flume and also helped in dissipating the excess energy of flow. The sand bed had a thickness of 30 cm. The sand used in the experiments reported herein has mean size of $d_{50} = 0.75$ mm and standard deviation of $\sigma_g = 1.94$. The groin models used in the study were fabricated by wooden. The groin model was bell mouth type. The groin was positioned with different angle of inclination of 60° , 90° , 135° and 150° with the downstream. A total number of 24 test runs were conducted. Three different discharge and two groin condition (submerged and non-submerged) was considered. Twelve tests were conducted for non-submerged conditions of which 6 (six) tests were with 14 cm depth and 6 (six) tests were with 18 cm depth. Similarly, another 12 (twelve) tests were conducted with submerged condition of which 6 (six) had a water depth of 22 cm and the rest six had a flow depth of 26 cm. To obtain a specific discharge, water level was maintained by adjusting the tailgate on downstream. The water discharge has been measured at two sharp-crested Rehbock weirs, one between the upstream reservoir and the flume and one in the recirculation channel. Only the Rehbock weir located at the re-circulating canal has been used to measure the discharge on a routine basis at half hour intervals. The discharge has been calculated from reading of point gauge in the adjacent stilling basin using the following equation.

$$Q = \frac{2}{3} * C_d * L_{weir} * \sqrt{2g} * (\Delta H)^{\frac{3}{2}} \quad (1)$$

The free flow has been ensured only at the downstream weir and coefficient of discharge (C_d) has been calculated to be 0.6.

Water depths were measured at one-hour intervals by the help of a point-gauge mounted on a wooden frame. Flow velocity measurements were obtained by using programmable electromagnetic velocity meter (P-EMS) consisting of a 50 mm-diameter probe and a control unit, mounted on a movable measuring carriage. The sensor of this instrument determines flow velocity components in two dimensions. P-EMS positions and readings were calibrated daily, as the instrument was removed every evening and re-installed every morning to prevent theft. Details of selected experimental runs are given in Table 1. Each test was designated by certain notations. For example Test no.1 is designated by 170-S-150, it mean that the test was conducted at a discharge of 170 l/s, submerged condition with the groin placed at 150° angle in direction towards downstream. All others tests have been similarly designated.

Each velocity reading has been taken as the average velocity of 30 seconds duration. Two velocity components, i.e. streamwise velocity (V_x) and transverse velocity (V_y), with standard deviations are read from the display screen of the control unit at a time. Grid point layout in XY plane at 0.2, 0.4, 0.6 and 0.8 depths from the water surface is formed and velocity has been measured on the selected grid. In each layer-grid, 120 velocity measurements have been collected, hence for 4-layers in one test run, 480 data on velocity have been collected. In this paper the results of test runs conducted under submerged conditions for 150° and 90° angles are reported. The grid point layout for velocity measurement in XY plane for two bell mouth groin arrangements are shown in Figure 1 & 2 respectively.

Co-ordinate system

A Cartesian co-ordinate system has been chosen and used during the experimentation in the flume as shown in Fig. 3. The schematic diagram shown in Fig. 3 is self explanatory. The test runs conducted under this research program and the various important information of the test program are presented in Table 1.

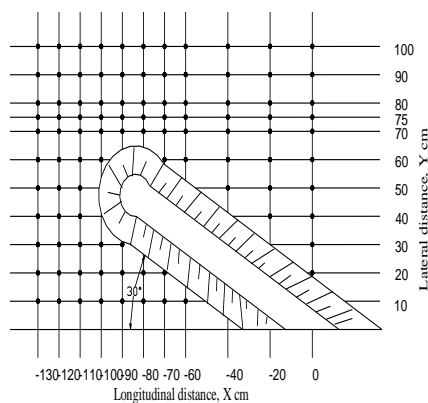

Fig. 1. Grids for velocity measurement for 150° angle

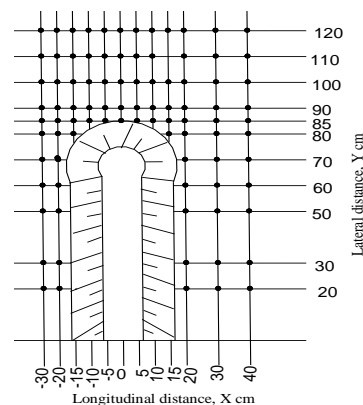

Fig. 2. Grids for velocity measurement for 90° angle

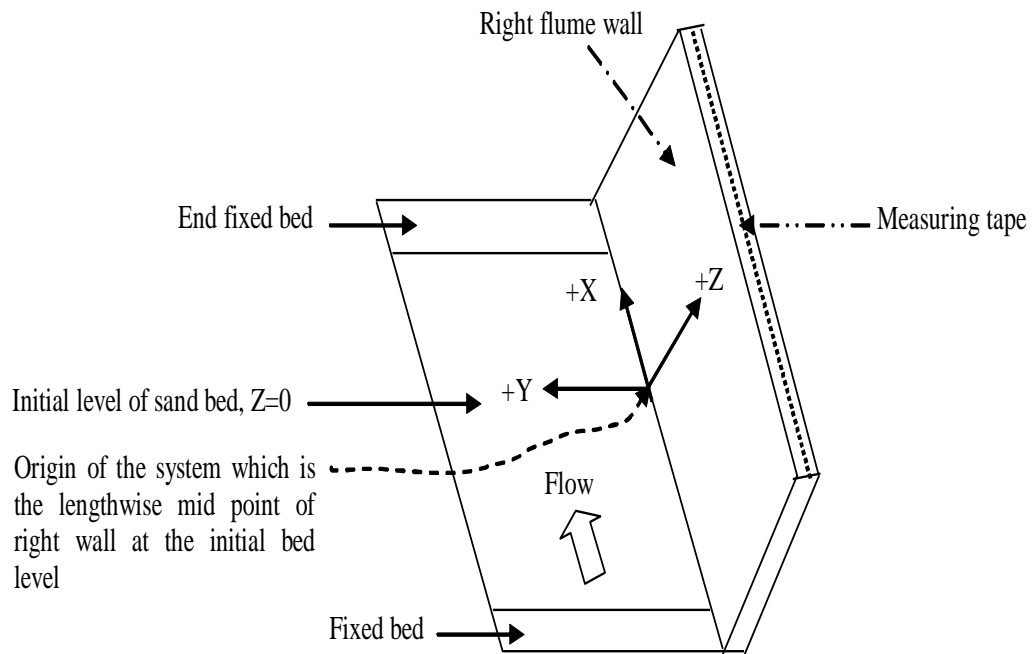

Fig. 3. Coordinate system used in the experiment

Bell mouth groin dimensions

The top width of the bell mouth groin was 12.5 cm and bottom width was 32.5 cm on the bed level. The height of groin above the bed surface is 20 cm and below the bed level was 40 cm. The top diameter at head of the groin is 15 cm and at base on the bed level is 35 cm. Shank and head slope is 2V:1H. All the dimension of the bell mouth groin above the bed surface was shown in the Fig. 4.

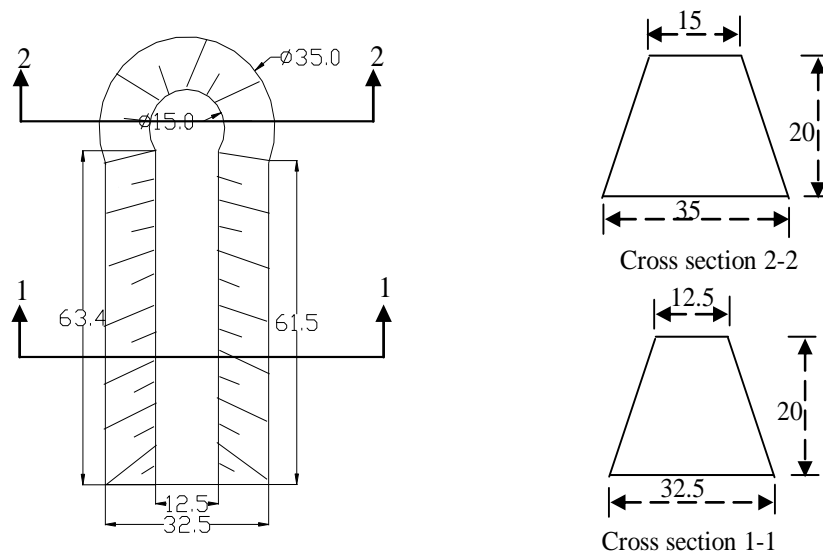

Fig. 4. Bell mouth groin dimension above the bed level (All dimensions are in cm)

Table 1. Summary of the test program

| Test No. | Test Designation | Discharge (lit/sec) | Angle of attack (degree) | Water depth (cm) |
|----------|------------------|---------------------|--------------------------|------------------|
| 1 | 170-NS-150 | 170 | 150 | 14 |
| 2 | 150-NS-150 | 150 | | |
| 3 | 130-NS-150 | 130 | | |
| 4 | 170-S-150 | 170 | | 22 |
| 5 | 150-S-150 | 150 | | |
| 6 | 130-S-150 | 130 | | |
| 7 | 170-NS-135 | 170 | 135 | 18 |
| 8 | 150-NS-135 | 150 | | |
| 9 | 130-NS-135 | 130 | | |
| 10 | 170-S-135 | 170 | | 26 |
| 11 | 150-S-135 | 150 | | |
| 12 | 130-S-135 | 130 | | |
| 13 | 170-NS-90 | 170 | 90 | 14 |
| 14 | 150-NS-90 | 150 | | |
| 15 | 130-NS-90 | 130 | | |
| 16 | 170-S-90 | 170 | | 22 |
| 17 | 150-S-90 | 150 | | |
| 18 | 130-S-90 | 130 | | |
| 19 | 170-NS-60 | 170 | 60 | 18 |
| 20 | 150-NS-60 | 150 | | |
| 21 | 130-NS-60 | 130 | | |
| 22 | 170-S-60 | 170 | | 26 |
| 23 | 150-S-60 | 150 | | |
| 24 | 130-S-60 | 130 | | |

RESULTS AND DISCUSSIONS

Velocity variation along longitudinal direction

Fig. 5 shows the variation of streamwise velocity at $Y/h=3.25$ (65cm away from right) in longitudinal direction for 150° angle. From this Fig. it was found that the maximum velocity gains at the $-4.0h$ distance i.e. around head of the bell mouth groin. Fig. 6 shows the variation of streamwise velocity at $Y/h=4.25$ (85 cm away from right) in longitudinal direction for 90° angle. From this Fig. it was found that streamwise velocity increase still the mid width of the bell mouth groin ($X/h=0$) and then decreases up to $1h$ distance and gradually regaining its original velocity after traveling downstream distance. This may be happened due to separation of flow at upstream face of bell mouth groin.

The variations of transverse velocity at $Y/h=3.25$ (65 cm away from right) in longitudinal direction are presented in Fig. 7 for 150° angle. The trends of the curve for all vertical depths are almost same. It was found from this Fig. that for all vertical depth the curve have tendencies to increasing pattern upto $4.5h$ distance and after than the transverse velocity decreases laterally. The variations of transverse velocity at $Y/h=4.25$ in longitudinal direction are presented in Fig. 8 for 90° angle. In general the trends of the curve are almost same for all the discharges. It was found from this Figure that there is tendency to increasing velocity around the head of the bell mouth groin. The reason may be that mean velocities increases due to constriction of flow around the head of groin.

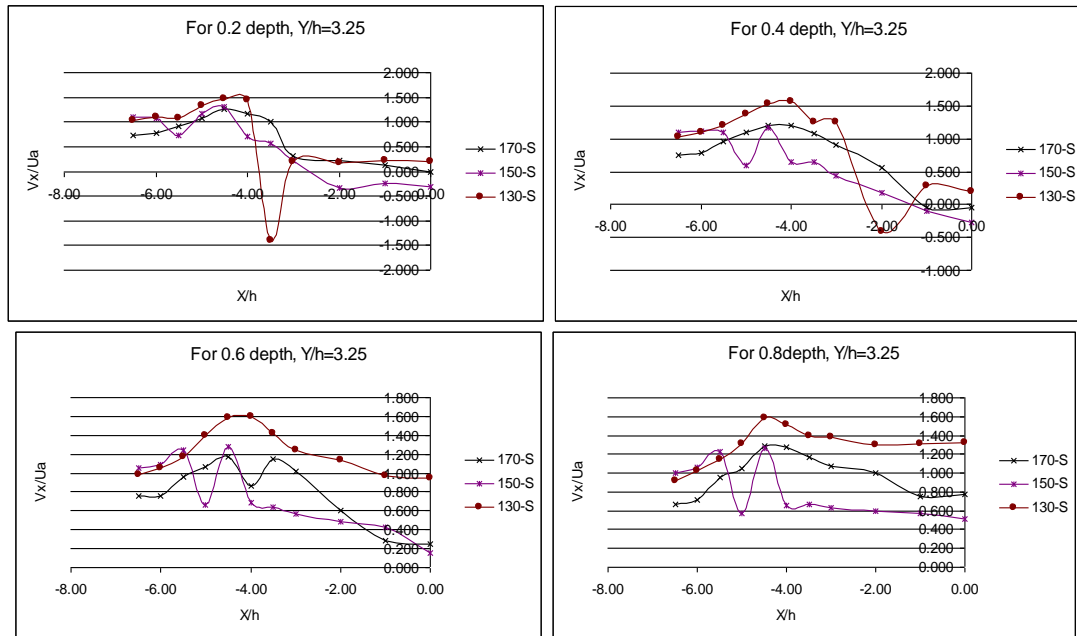

Fig. 5. Variation of streamwise velocity (V_x) at $Y/h=3.25$ in longitudinal direction (X) for 150° degree angle

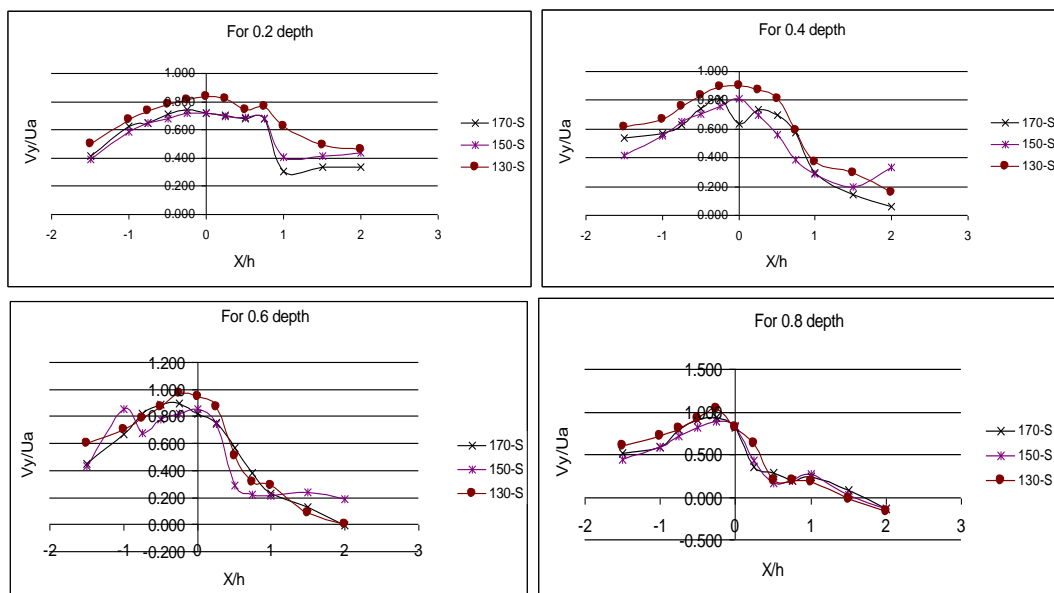

Fig. 6. Variation of streamwise velocity (V_x) at $Y/h=4.25$ in longitudinal direction (X) for 90 degree angle

Velocity variation along lateral direction

The variations of streamwise velocity at $X/h=-5.5$ (105cm upstream from centre of groin) in lateral direction are presented in Fig. 9 for 150° angle. It was found that the variation of streamwise velocity for four vertical depth from the water surface, the tendency of the curve al-most increasing to the lateral direction. It may be caused due to shifting of velocity from right to left touching the head of structure. The variations of streamwise velocity at $X/h=2$, in lateral direction are presented in Fig. 10 for angle 90° angle. From this Fig. it was observed that from 1h to 4h distance velocity variation almost uniform. From 4h to 5h distance (around head of the groin) velocity variation is increasing pattern to the lateral direction. This may be occurs due to passing the flow adjacent to the head of the groin. The most significant observation that can be made from all this Figs. is the lateral shifting of maximum velocity away from the head of the bell mouth groin. This lateral shifting of velocity is evidently related with the shifting of discharge away from the bell mouth groin.

The variations of transverse velocity at $X/h=-5.5$ (105 cm upstream from centre of groin) in lateral direction are presented in Fig. 11 for 150° angle. It shows that the transverse velocity increases at the vicinity of the head of the bell mouth groin at 3h distance and then decreases laterally. The variations of transverse velocity at $X/h=2$, in lateral direction are presented in Fig. 12 for 90° angle. It appears that at downstream of the bell mouth groin it was found that the most generalized trend is an increase in transverse velocity at 0.2 depth compared to other vertical depths. The presence of positive and negative velocity provides the evidence of the existence of a circulation behind the bell mouth groin.

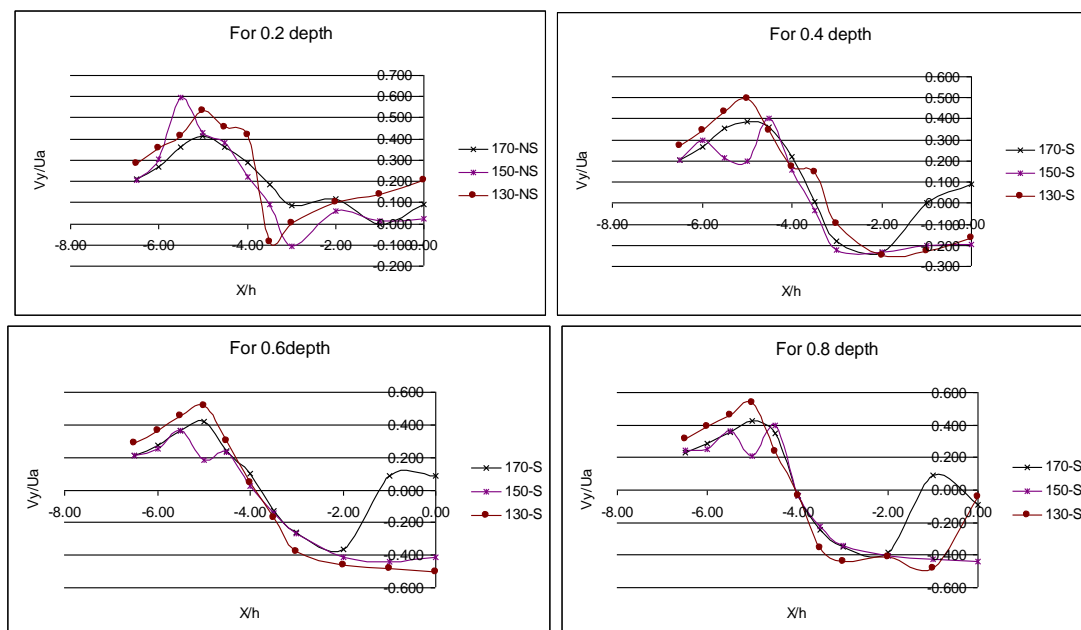

Fig. 7. Variation of transverse velocity (V_y) at $Y/h=3.25$ in longitudinal direction (X) for 150 degree angle

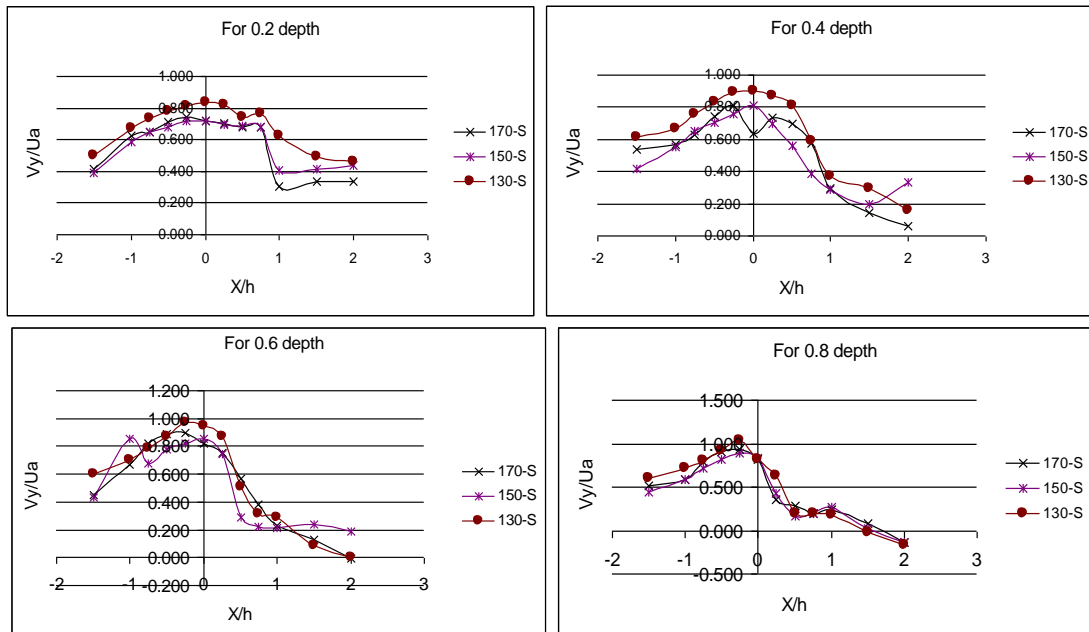

Fig. 8. Variation of transverse velocity (V_y) at $Y/h=4.25$ in longitudinal direction (X) for 90 degree angle

Velocity variation along vertical direction

The streamwise velocity profile in the vertical direction has been shown in Fig. 13 for 150° angle and in Fig. 14 for 90° angle at $Y/h=4.25$ (85cm away from right) and $Y/h=3.25$ (65cm away from right) respectively. The streamwise vertical velocity profile clearly indicates a downward movement of flow at front face of structure. In most cases, streamwise vertical velocity in lower part of the channel is found higher than that of upper part. This increasing and decreasing pattern is also clearly associated with vortex generation and may be responsible for scouring around structure. Streamwise velocity profile has been found variable with different discharges and does not follow its natural logarithmic pattern. It may be caused due to creation of a complex flow field by interaction between flow and structure.

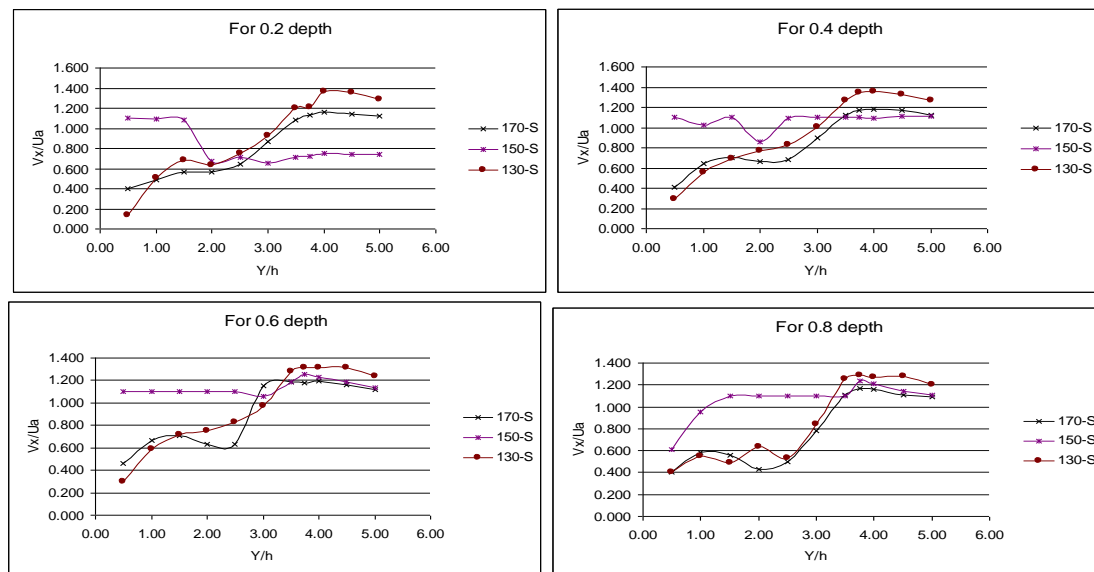

Fig. 9. Variation of streamwise velocity (V_x) at $X/h=-5.5$ in lateral direction (Y) for 150 degree angle

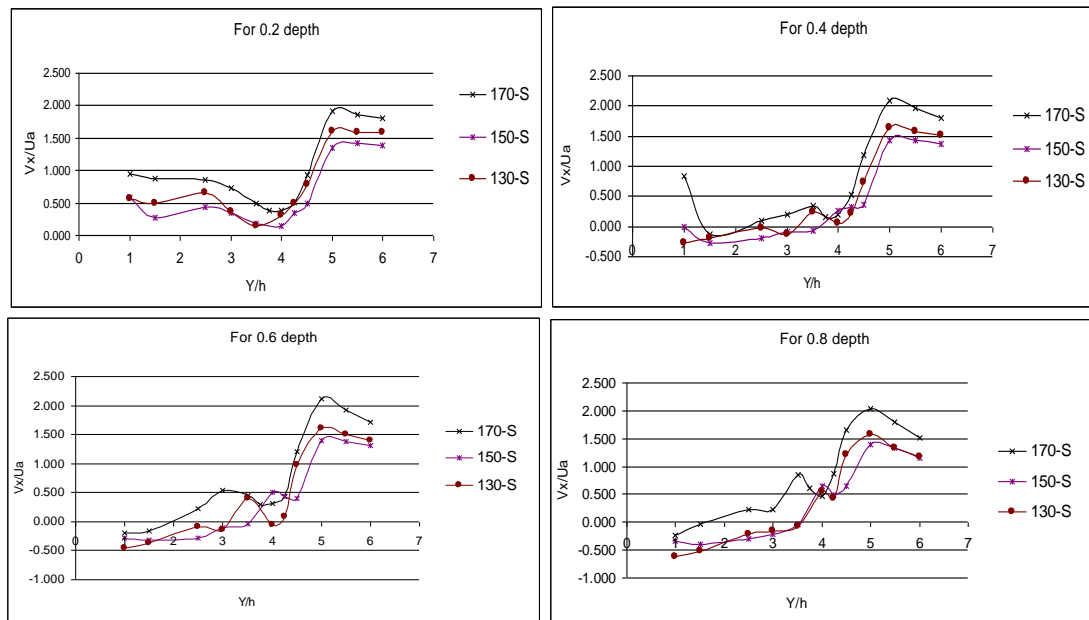

Fig. 10. Variation of streamwise velocity (V_x) at $X/h=2$ in lateral direction (Y) for 90 degree angle

Velocity vector diagram

Resultant velocity vector diagrams in XY plane at four vertical depths for variable discharges have been represented in Fig. 15 to 32. From velocity vector (Both for 150° and 90°) it was found that flow is steady at upstream along longitudinal direction. The flow is just diverted in head of structure and flows through sides of structure towards downstream. The flow velocity reaches near about zero at front face of structure, which may cause due to a down flow at upstream face of groin. Breusers and Raudkivi stated that at upstream of structure, approach flow velocities go to zero and stagnation pressure decreases [13]. This caused a downward pressure gradient that drives down-flow at upstream face of structure. Down-flow acts like a vertical jet and removes sediment at of structure. For 150° groin angle, the following observation can be made: (i) the flow vector near the head is firstly deviated away from the head and again deviated towards the groin after passing the head of groin. (ii) A circulation of flow has been observed around head of structure after diverting of flow towards down. This may occurred due to horseshoe vortex. This may occurred due to horseshoe vortex. This circulation is relatively strong near surfaces & weak near bed. According to Melville (1997), horseshoe vortex forms due to separation of flow at upstream rim of scour hole [14].

For 90° groin angle, the following observation can be made: (i) the flow vector is deviated away from the head near the groin head. (ii) Immediately after rear front of structure, relatively weak circulation of flow has been observed. This may be indication of vertical vortices formation, called wake vortex. Wake vortex is also responsible for downstream scour with horseshoe vortex as these vortices are translated downstream by mean flow and act like vacuum cleaners sucking up sediment from bed and also transporting sediment entrained by down flow and horseshoe vortex. After leaving rear face of structure, flow is found becoming steady gradually with traveling to far downstream.

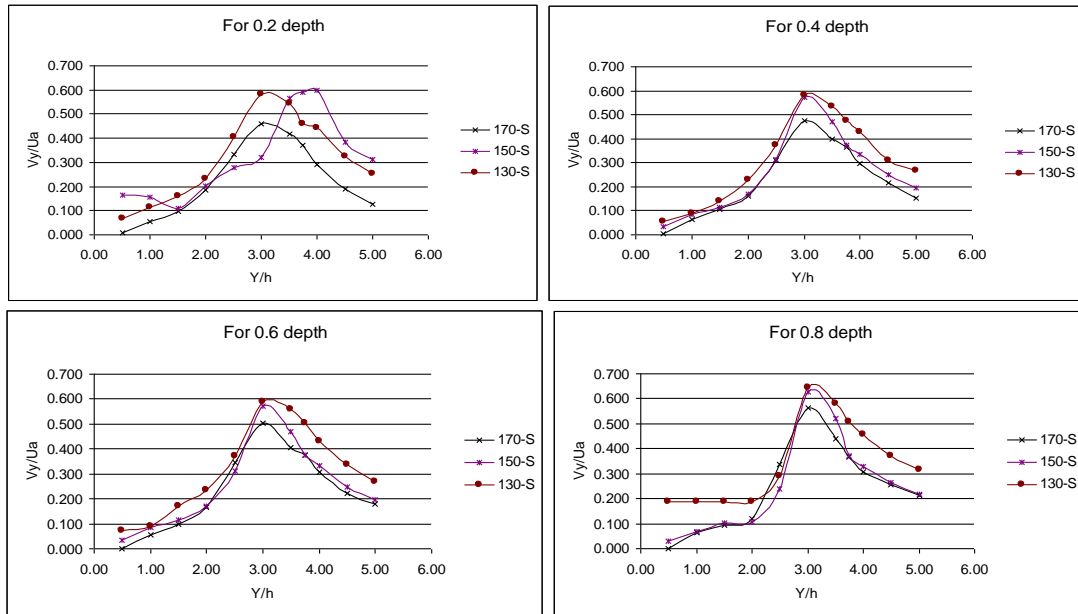

Fig. 11. Variation of transverse velocity (V_y) at $X/h=-5.5$ in lateral direction (Y) for 150 degree angle

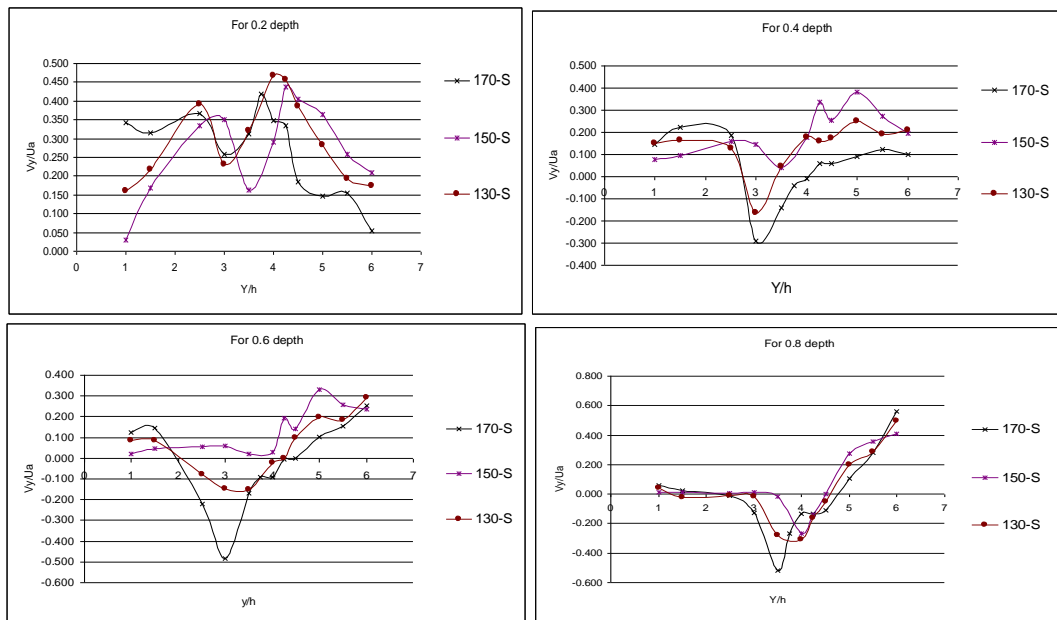
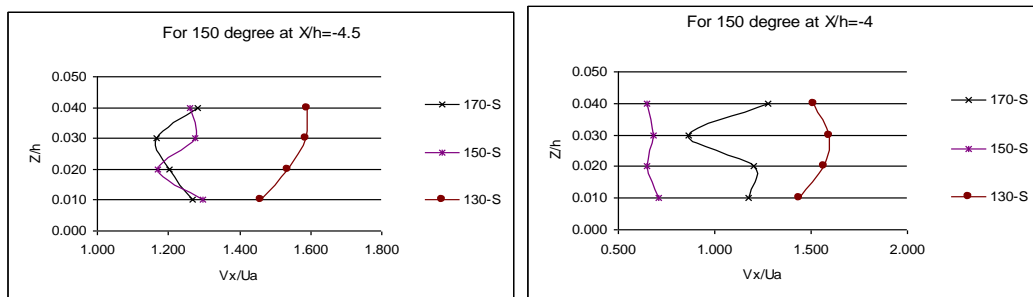

Fig. 12. Variation of transverse velocity (V_y) at $X/h=2$ in lateral direction (Y) for 90 degree angle



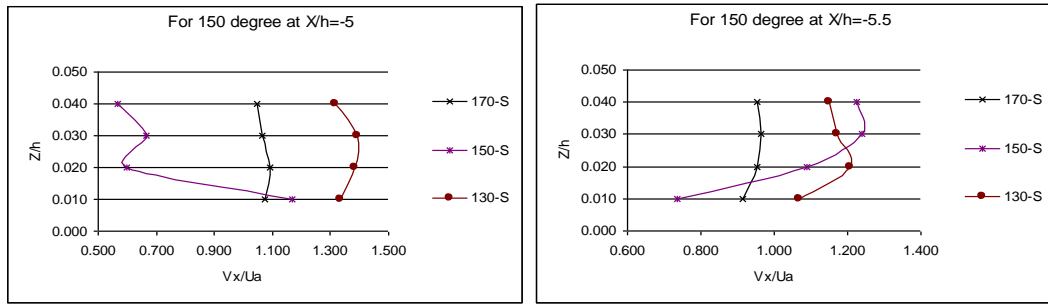

Fig. 13. Vertical variation of streamwise velocity (V_x) at $Y/h=3.25$ for 150 degree angle

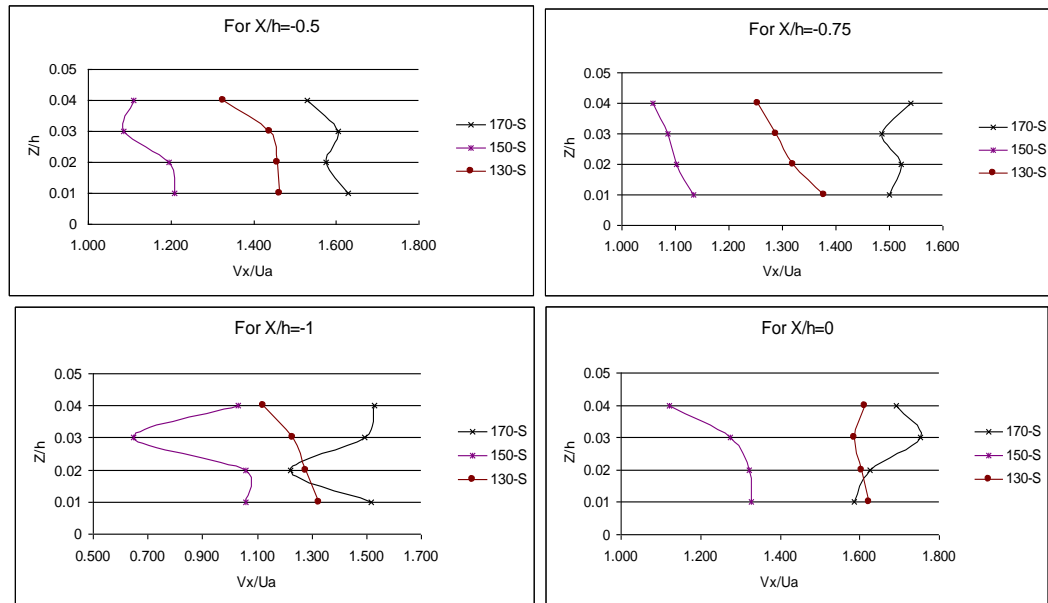

Fig. 14. Vertical variation of streamwise velocity (V_x) at $Y/h=4.25$ for 90 degree angle.

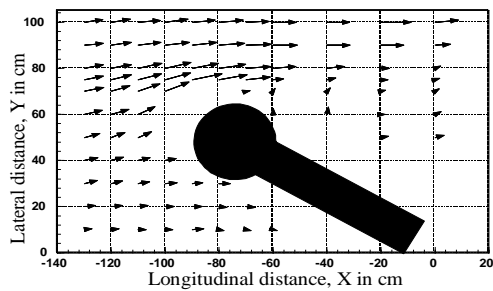

Fig. 15. Velocity vector at 0.2 depths for 170-S-150

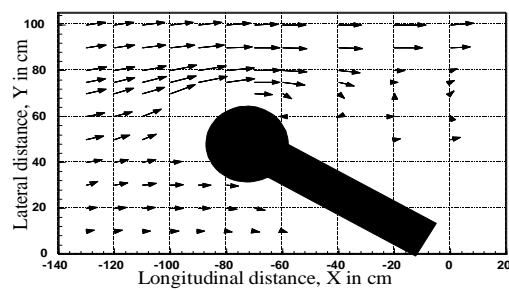

Fig. 16. Velocity vector at 0.4 depths for 170-S-150

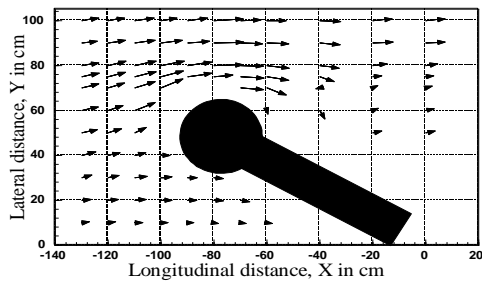

Fig. 17. Velocity vector at 0.6 depths for 170-S-150

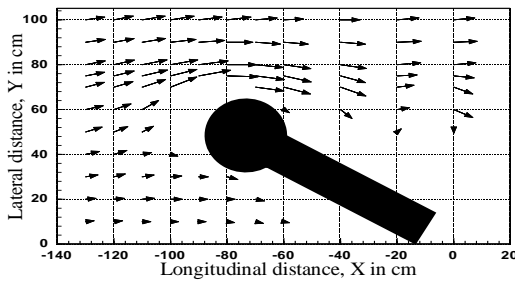

Fig. 18. Velocity vector at 0.8 depths for 170-S-150

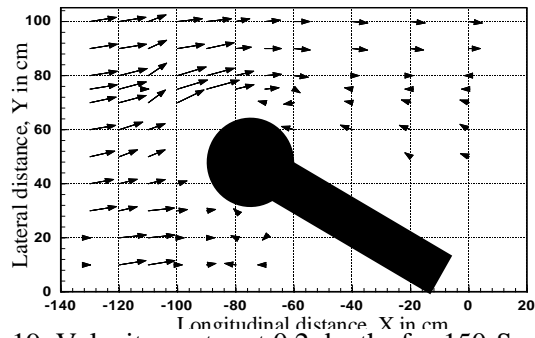

Fig.19. Velocity vector at 0.2 depths for 150-S-150

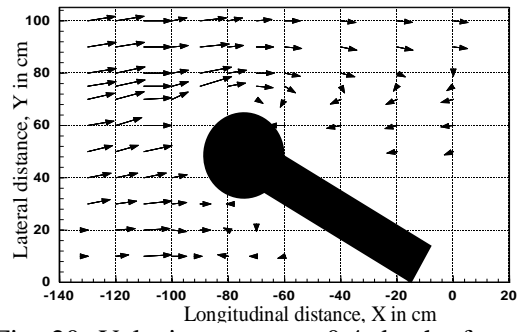

Fig. 20. Velocity vector at 0.4 depths for 150-S-150

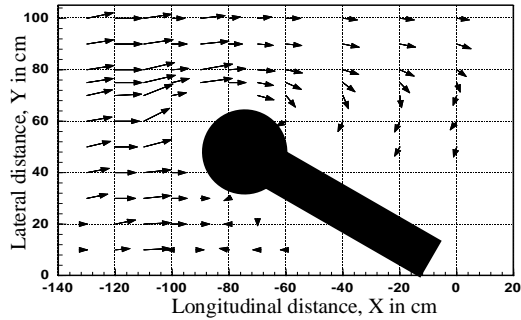

Fig. 21. Velocity vector at 0.6 depths for 150-S-150

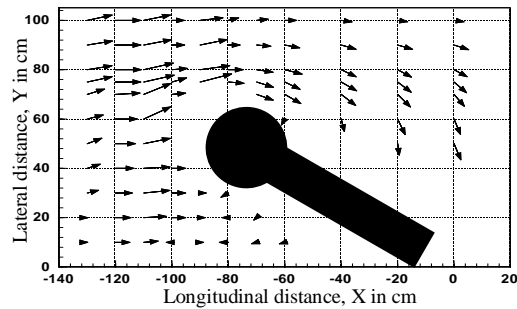

Fig. 22. Velocity vector at 0.8 depths for 150-S-150

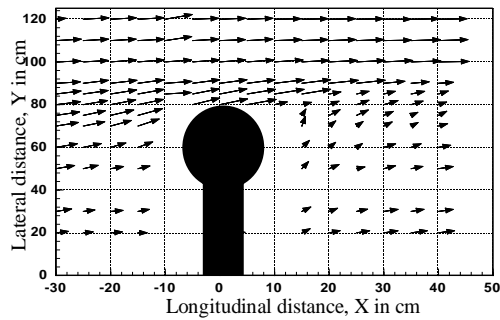

Fig. 23. Velocity vector at 0.2 depths for 170-S-90

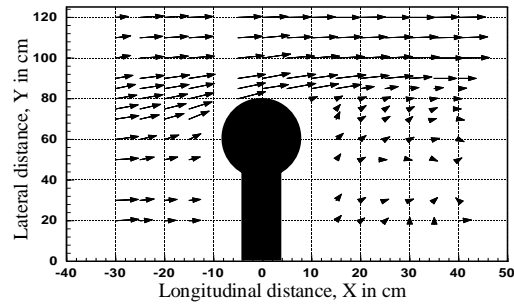

Fig. 24. Velocity vector at 0.4 depths for 170-S-90

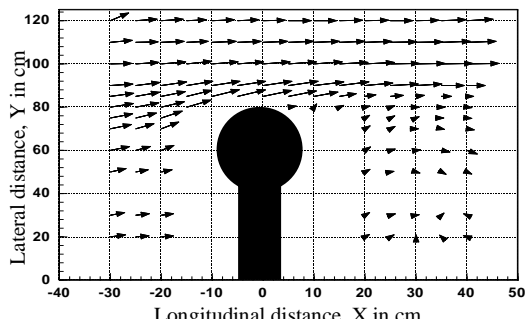

Fig. 25. Velocity vector at 0.6 depths for 170-S-90

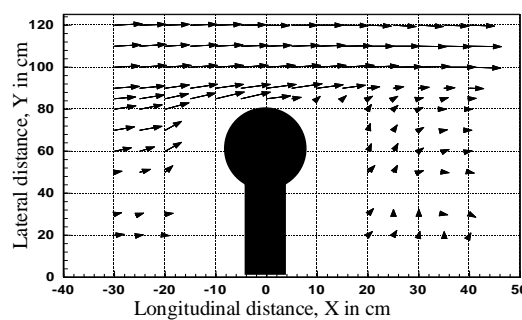

Fig. 26. Velocity vector at 0.8 depths for 170-S-90

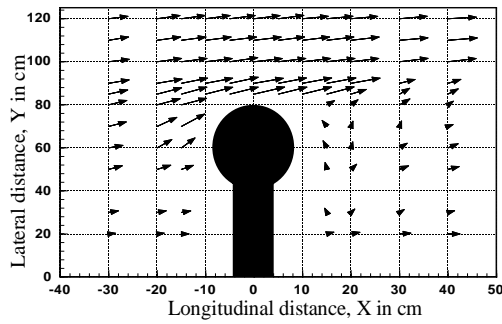

Fig. 27. Velocity vector at 0.2 depths for 150-S-90

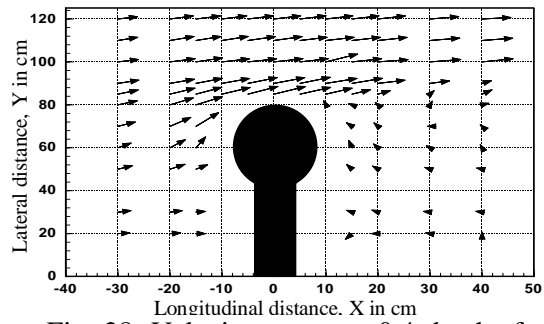

Fig. 28. Velocity vector at 0.4 depths for 150-S-90

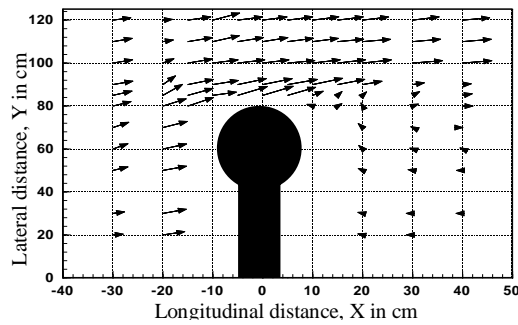

Fig. 29. Velocity vector at 0.6 depths for 150-S-90

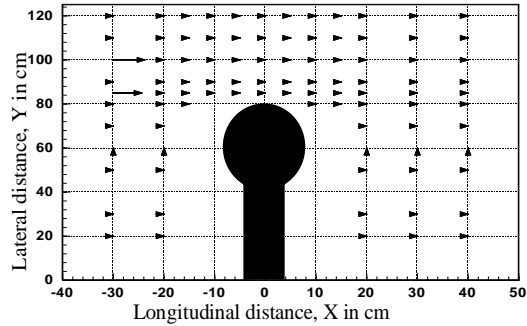

Fig. 30. Velocity vector at 0.8 depths for 150-S-90

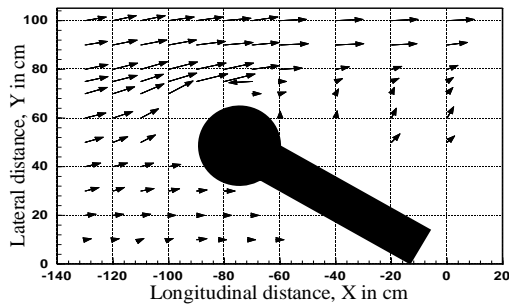

Fig. 31. Velocity vector at 0.2 depths for 130-S-150

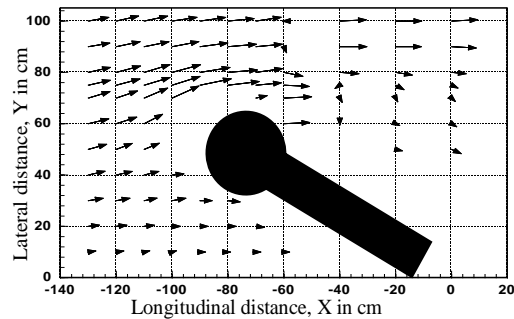

Fig. 32. Velocity vector at 0.4 depths for 130-S-150

CONCLUSIONS

The streamwise velocity along lateral direction was found that the lateral shifting of maximum velocity away from the head of the bell mouth groin. In most cases, streamwise vertical velocity in lower part of the channel is found higher than that of upper part. Streamwise vertical velocity profile has been found variable with different discharges and does not follow its natural logarithmic pattern. Velocity vector indicates that flow is steady at upstream along longitudinal direction. The flow diverted at head of structure and flows through sides of structure towards downstream. For 150° groin angle, it was found that the flow vector near the head is firstly deviated away from the head and again deviated towards the groin after passing the head of groin. A circulation of flow has been observed around head of structure after diverting of flow towards down. This may occurred due to horseshoe vortex. This circulation is relatively strong near surfaces & weak near bed. For 90° groin angle, it was found that the flow vector is deviated away from the head near the groin head. Immediately after rear front of structure, relatively weak circulation of flow has been observed. This may be indication of vertical vortices formation, called wake vortex. Wake vortex is also responsible for downstream scour

with horseshoe vortex as these vortices are translated downstream by mean flow and act like vacuum cleaners sucking up sediment from bed and also transporting sediment entrained by down flow and horseshoe vortex. After leaving rear face of structure, flow is found becoming steady gradually with traveling to far downstream.

REFERENCES

- [1] Shields J F D, Cooper C M, & Knight S S, Experiment in Stream Restoration. *Journal of Hydraulic Engineering*, ASCE 121(6)(1995)494.
- [2] Rahman M M, & Muramoto Y., Prediction of Maximum Scour Depth around Spur-Dike-Like Structures. *Annual Journal of Hydraulic Engineering, JSCE* 43. (1999) 623.
- [3] Ishigaki T & Baba, Y, Local Scour Induced by 3D Flow around Attracting and Deflecting Groins. *Proceedings of Second International Conference on Scour and Erosion*, Meritus Mandarin, Singapore, (2004) 301.
- [4] Khaleduzzaman A T M, *Experimental Study on River Course Stabilization and Restoration by using Groin-like Structures*. Master thesis Kyoto University, Japan, 2004.
- [5] Hossain M M, *Study of River Bank Stabilization in a Bend by Groin*. M.Sc. Thesis, BUET, Dhaka, Bangladesh, 1981.
- [6] Muto Y, Kitamura K, Baba Y, & Nakagawa H, Field Measurement of Velocity Distribution in Groin Fields with ADCP. *Annual Journal of Hydraulic Engineering, JSCE* 49, (2005).
- [7] Uijtewaal W S J, Lehman D & Van Mazijk A, Exchange Process Between a River and Its Groin Fields: Model Experiment. *Journal of Hydraulic Engineering*, 127 (11)(2001)122.
- [8] Kabir M A, *An Experimental Study on the Effect of Submerged Vane on Scour and Flow around Abutment*. M.Sc. Thesis, Department of Water Resources Engg., BUET, Dhaka, 2007.
- [9] Rahman, M M, Haque M A, & Alam A A, Flow Field Around Piers and Abutments at the Initiation of Scouring. *Proceedings of the 1st International Conference on Civil Engineering*, IEB and FEISCA, Chittagong, 2-3 Nov., 2001, 403-410.
- [10] Rahman M M, Haque M A, & Islam M S, Flow and Scouring around Piers and Abutments. *13th IAHR-APD Congress*, Singapore (2002) 280.
- [11] Ahmad M, Experiments on design and behavior of spur-dikes. *Proc. Int. Hydraul. Convention*, (1953)145.

- [12] Liu, M K, Chang F M, & Skinner M M, *Effect of bridge construction on scour and backwater*, Department of Civil Engineering, Colorado State University, Fort Collins, Colorado, (1961) Report No. CER60-HKL22.
- [13] Breusers H N C, Time scale of two-dimensional local scour. Proc. 12th Cong. IAHR 3(1991)275.
- [14] Melville, B.W.. Pier and abutment scour: integrated approach. *Journal of Hydraulic Engineering, ASCE*, 123(2)(1997) 125.